

CARB toroidal roller bearings

A revolutionary concept

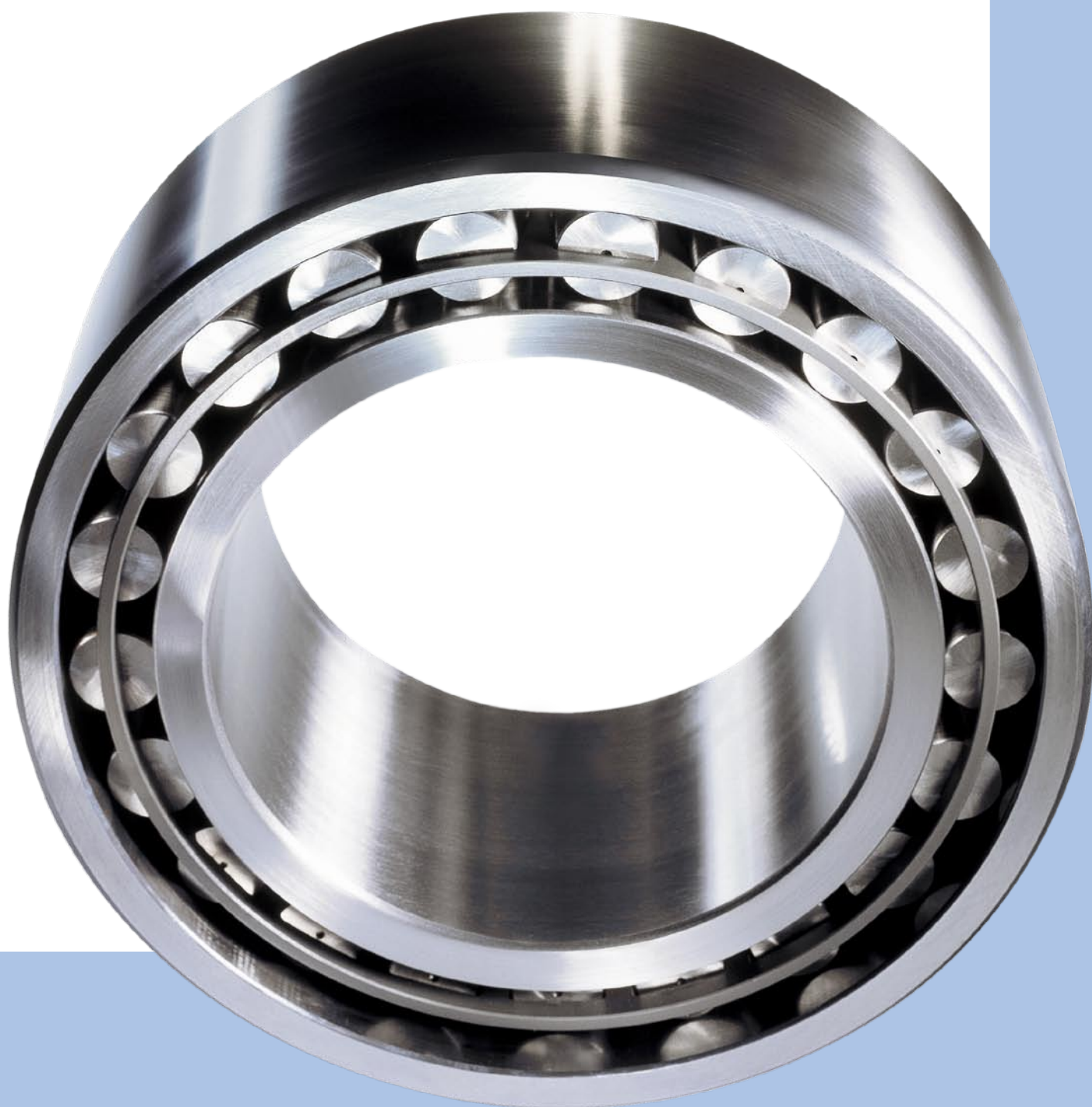



The SKF brand now stands for more than ever before, and means more to you as a valued customer.

While SKF maintains its leadership as the hallmark of quality bearings throughout the world, new dimensions in technical advances, product support and services have evolved SKF into a truly solutions-oriented supplier, creating greater value for customers.

These solutions encompass ways to bring greater productivity to customers, not only with breakthrough application-specific products, but also through leading-edge design simulation tools and consultancy services, plant asset efficiency maintenance programmes, and the industry's most advanced supply management techniques.

The SKF brand still stands for the very best in rolling bearings, but it now stands for much more.

SKF – the knowledge engineering company

Contents

A Product information

- 3 **The winning combination**
- 4 **CARB toroidal roller bearings with revolutionary design characteristics**
- 5 SKF Explorer class bearings
- 6 **A range for all requirements**
- 7 Availability
- 7 Bearing benefits
- 8 **The CARB toroidal roller bearing – the cornerstone of the SKF self-aligning bearing system**
- 8 The conventional solution
- 9 The SKF solution
- 10 **Successful in service**

B Recommendations

- 12 **Selection of bearing size**
- 12 Longer life or downsizing
- 14 **Design of bearing arrangements**
- 14 Radial location
- 16 Axial location
- 18 Design of adjacent components
- 20 Sealing the bearing arrangement
- 22 **Lubrication**
- 22 Grease lubrication
- 24 Deviating conditions
- 25 Oil lubrication
- 26 **Mounting**
- 26 Mounting on a cylindrical seat
- 26 Mounting on a tapered seat
- 34 **Dismounting**
- 34 Dismounting from a cylindrical seat
- 35 Dismounting from a tapered seat
- 36 **The SKF concept for cost savings**

C Product data

- 37 **Bearing data – general**
- 44 **Product tables**
- 44 CARB toroidal roller bearings
- 56 Sealed CARB toroidal roller bearings
- 58 CARB toroidal roller bearings on an adapter sleeve
- 68 CARB toroidal roller bearings on a withdrawal sleeve

D Additional information

- 78 **Other associated SKF products**
- 82 **SKF – the knowledge engineering company**

The winning combination

Self-alignment ...

Self-aligning bearings are the hallmark of SKF – not surprising since SKF was founded in 1907, based on the invention of the self-aligning ball bearing by Sven Wingquist. But the development did not stop there, other SKF inventions followed: the spherical roller bearing in 1919 and the spherical roller thrust bearing in 1939.

Self-alignment is called for

- when misalignment exists as a result of inaccurate manufacturing or mounting errors
- when shaft deflections occur under load

and these have to be accommodated in the bearing arrangement without negative effects on performance or any reduction in bearing service life.

... and axial displacement ...

SKF was also heavily involved in the development of bearings having rings that can be axially displaced relative to each other. In 1908, for example, the cylindrical roller bearing in its modern version was developed to a large extent by Dr.-Ing. Josef Kirner of the Norma Compagnie in Stuttgart-Bad Cannstatt, which became a subsidiary of SKF.

Cylindrical roller bearings are applied when

- heavy radial loads and relatively high speeds prevail
- thermal changes in shaft length must be accommodated within the bearing with as little friction as possible – provided, of course, that there is no significant misalignment.

... combined for success

In the past, almost every bearing arrangement was a compromise due to misalignment and shaft deflections. In most cases, depending on the load and speed requirements, design engineers were limited to self-aligning ball bearings or spherical roller bearings.

Though these bearings could accommodate misalignment, they could not accommodate axial displacement within the bearing like a cylindrical roller bearing. Therefore, it was necessary for one of the bearings to move axially on its seat in the housing. This movement, which took place under considerable friction, produced additional axial forces in the bearing arrangement. The result was a shortened bearing service life and relatively high maintenance and repair costs.

Today, this scenario is a thing of the past because Magnus Kellström, a product designer at SKF, had the brilliant idea to create a bearing that could compensate for misalignment without friction like a spherical roller bearing, and accommodate changes in shaft length internally, like a cylindrical roller bearing.

This completely new type of bearing, called a toroidal roller bearing gives engineers an opportunity to design bearing arrangements without compromise. Additional benefits include much longer service life for the complete bearing arrangement and minimized maintenance and repair costs.

Self-alignment ...

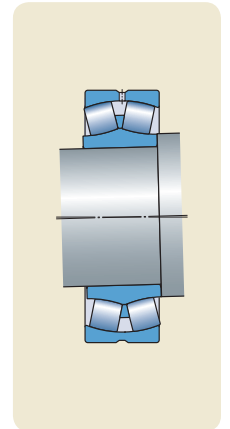

... and axial displacement ...

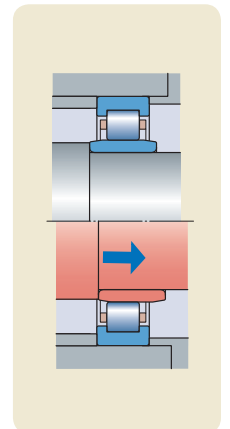

... combined in a toroidal roller bearing

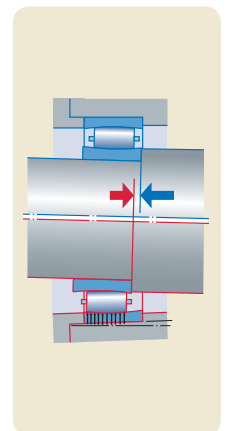

CARB toroidal roller bearings with revolutionary design characteristics

The CARB toroidal roller bearing represents one of the most important breakthroughs in rolling bearing technology over the past sixty years. The bearing was introduced to the market in 1995 under the SKF trademark CARB.

The CARB toroidal roller bearing is a completely new type of roller bearing, which offers benefits that were previously unthinkable. Irrespective of whether a new machine is to be designed or an older machine maintained, there are benefits to be gained by using a toroidal roller bearing. Which of these benefits is realized depends on the machine design and its operating parameters.

A CARB bearing is a single row roller bearing with relatively long, slightly crowned rollers. The inner and outer ring raceways are correspondingly concave and symmetrical (→ fig. 1). The outer ring raceway geometry is based on a torus (→ fig. 2), hence the term toroidal roller bearing.

The CARB toroidal roller bearing is designed as a non-locating bearing that combines the self-aligning ability of a spherical roller bearing with the ability to accommodate axial displacement like a cylindrical or needle roller bearing. Additionally, if required, the toroidal roller bearing can be made as compact as a needle roller bearing.

An application incorporating a CARB toroidal roller bearing provides benefits outlined in the following.

Self-aligning capability

The self-aligning capability of a CARB bearing is particularly important in applications where there is misalignment as a result of inaccurate manufacturing, mounting errors or shaft deflections. To compensate for these conditions, a CARB bearing can accommodate misalignment up to 0,5 degrees between the bearing rings without any detrimental effects on the bearing or bearing service life (→ fig. 3).

Axial displacement

Previously, only cylindrical and needle roller bearings could accommodate thermal expansion of the shaft within the bearing. Today, however, the CARB bearing has been added to that list (→ fig. 4). The inner and outer rings of a CARB bearing can be displaced, relative to each other, up to 10 % of the bearing width. By installing the bearing so that one ring is initially displaced relative to the other one, it is possible to extend the permissible axial displacement in one direction.

In contrast to cylindrical and needle roller bearings that require accurate shaft alignment, this is not needed for toroidal roller bearings, which can also cope with shaft deflection under load. This provides a solution to many problem cases.

Long bearing system life

The ability to accommodate misalignment plus the ability to accommodate axial displacement within the bearing with virtually no friction enables a CARB bearing to provide benefits to the bearing system and its associated components (→ fig. 5):

- Internal axial displacement is virtually without friction; there are no internally induced axial forces, thus operating conditions are considerably improved.
- The non-locating bearing as well as the locating bearing only need to support external loads.
- The bearings run cooler, the lubricant lasts longer and maintenance intervals can be appreciably extended.

Taken together, these benefits contribute to longer bearing system life.

The CARB toroidal bearing

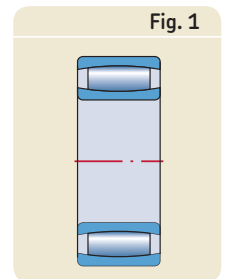

The torus

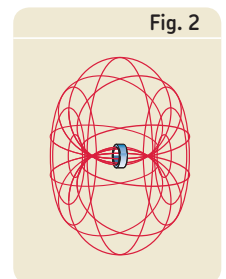

Angular misalignment

The most frequently occurring misalignments in operation are not a problem for a CARB toroidal roller bearing

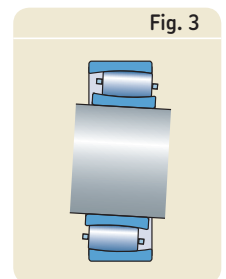

Axial displacement

Changes in shaft length are accommodated within the bearing, virtually without friction

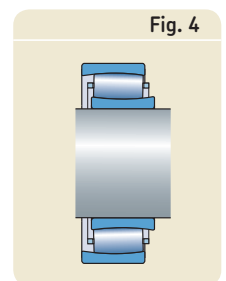

Freedom of movement

Permissible angular misalignment + axial displacement within the bearing

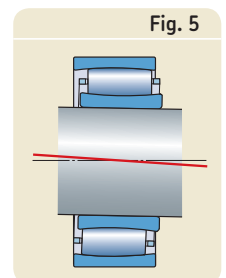

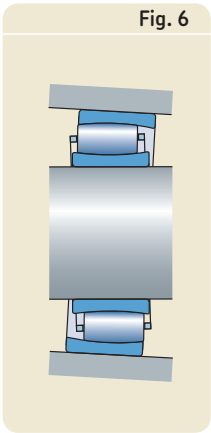

Fig. 6

Deviations from cylindrical form are less problematic
 Demands on accuracy of form of the bearing seats are less stringent, making simpler and less costly bearing arrangements possible

High load carrying capacity

CARB toroidal roller bearings can accommodate very heavy radial loads. This is due to the optimized design of the rings combined with the design and number of rollers. The large number of long rollers makes CARB bearings the overall strongest self-aligning radial roller bearings. Due to their robust design, CARB bearings can cope with small deformations and machining errors of the bearing seat (→ fig. 6). The rings accommodate these small imperfections without the danger of edge stresses. The high load carrying capacity plus the ability to compensate for small manufacturing or installation errors provide opportunities to increase machine productivity and uptime.

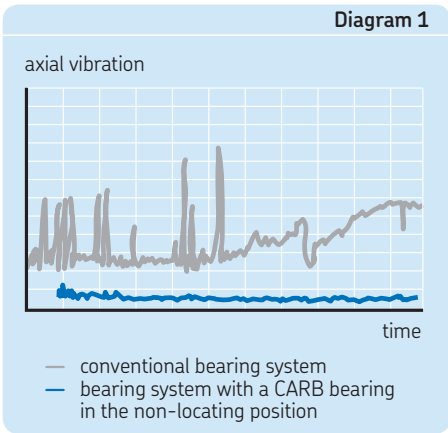

Diagram 1

Axial vibration

With a CARB bearing axial vibrations are considerably reduced, meaning longer service life and quieter operation

Improve performance or downsize

For bearing systems incorporating a CARB toroidal roller bearing as the non-locating bearing, internally induced axial loads are prevented. Together with high load carrying capacity this means that

- for the same bearing size in the arrangement, performance can be increased or service life extended
- new machine designs can be made more compact to provide the same, or even better performance.

Full dimensional interchangeability

The advantages of CARB bearing can be fully exploited when refurbishing non-locating bearing arrangements designed for self-aligning as well as rigid bearings

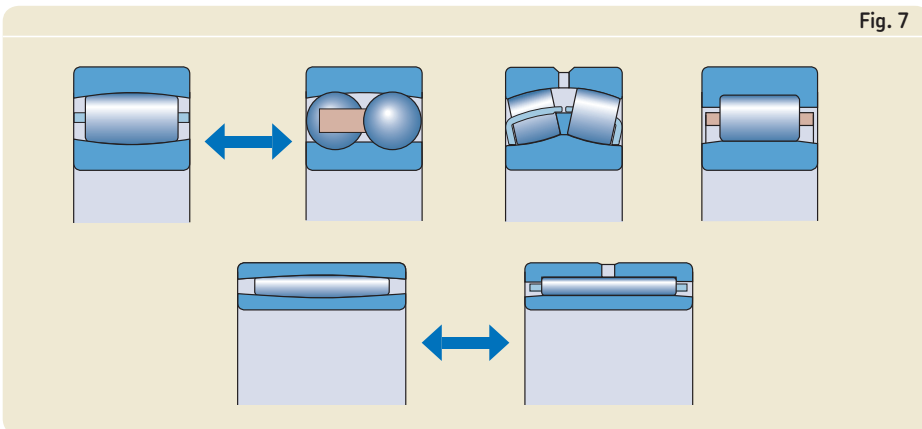

Fig. 7

Reduced vibration

Self-aligning ball or spherical roller bearings in the non-locating position need to be able to slide within the housing seat. This sliding, however, causes axial vibrations that can reduce bearing service life considerably.

Bearing arrangements that use CARB toroidal roller bearings as the non-locating bearing are stiff because CARB bearings can be radially and axially located in the housing and on the shaft. This is possible because thermal expansion of the shaft is accommodated within the bearing. The stiffness of the bearing arrangement, combined with the ability of the CARB bearing to accommodate axial movement, substantially reduces vibrations within the application to increase service life of the bearing arrangement and related components (→ diagram 1).

Full dimensional interchangeability

The boundary dimensions of CARB toroidal roller bearings are in accordance with ISO 15:1998. This provides full dimensional interchangeability with self-aligning ball bearings, cylindrical roller and spherical roller bearings in the same dimension series. The CARB bearing range also covers wide bearings with low cross sections normally associated with needle roller bearings (→ fig. 7).

SKF Explorer class bearings

All CARB bearings are manufactured to the SKF Explorer performance class.

A range for all requirements

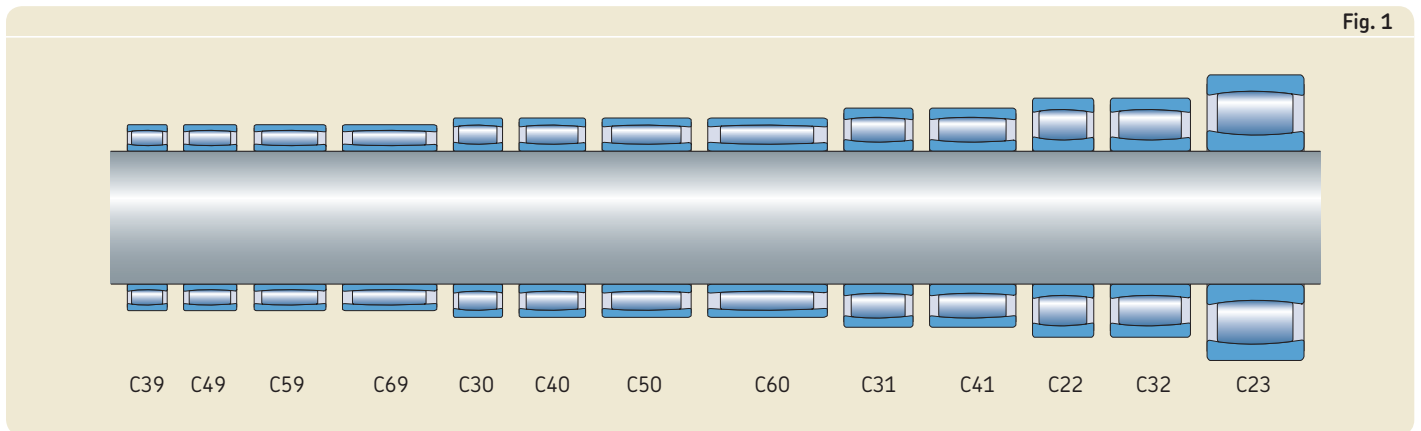

Overview of the product range

The SKF standard range of CARB toroidal roller bearings comprises bearings in 13 ISO dimension series (→ **fig. 1**). The smallest bearing has a bore diameter of 25 mm and the largest one a bore diameter of 1 250 mm. Bearings with a bore diameter up to 1 800 mm can be produced. Whether a new bearing arrangement is to be designed or an existing arrangement upgraded, most often there is an appropriate CARB toroidal roller bearing available or such a bearing could be manufactured.

CARB toroidal roller bearings are produced in

- a caged version (→ **fig. 2**)
- a full complement version (→ **fig. 3**)

with

- a cylindrical bore
- a tapered bore.

The tapered bore has a taper of 1:12 or 1:30, depending on the dimension series.

In addition to the standard bearings, SKF also produces special executions to suit particular applications, e.g.

- bearings with a case hardened inner ring, to avoid inner ring cracking and improve reliability in applications with heat, i.e. Yankee and drying cylinders in paper mills
- bearings with a surface hardened cage for vibrating screens
- sealed bearings, for example, for continuous casting plants (→ **fig. 4**). The possible misalignment and axial displacement as well as the load carrying capacity are lower than for a corresponding open bearing.

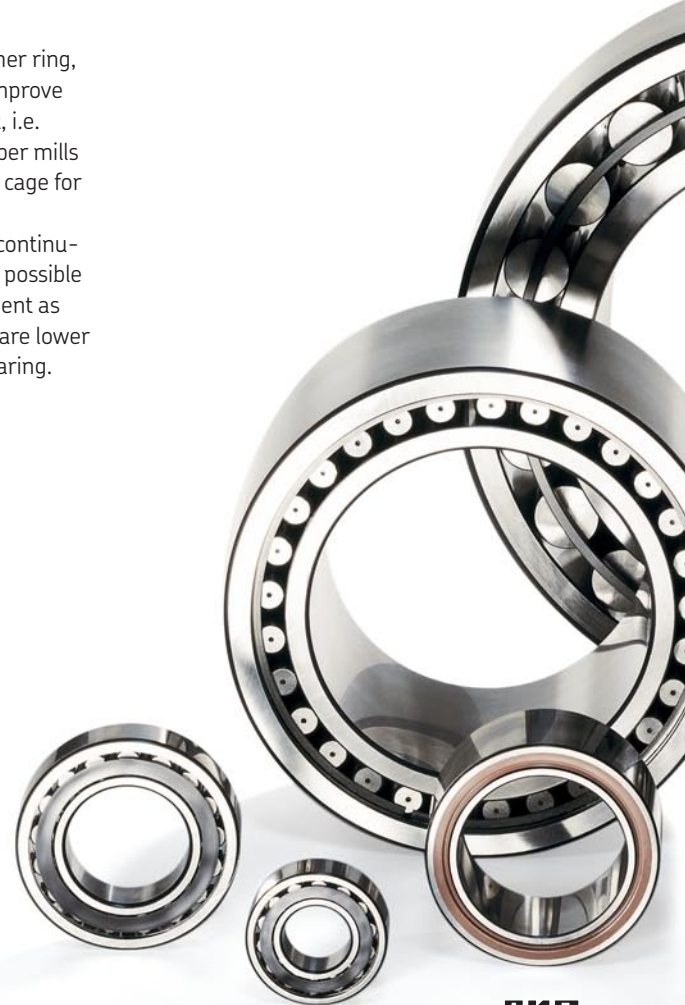

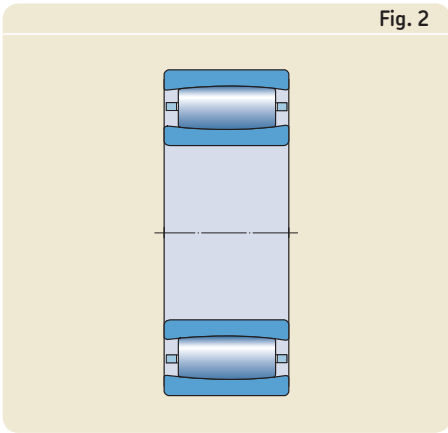

Caged bearing
For heavy loads and relatively high speeds

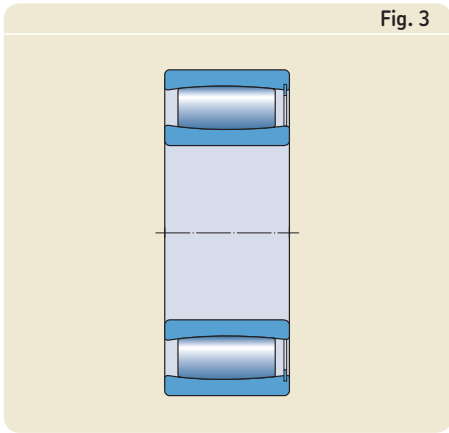

Full complement bearing
For very heavy loads and low speeds

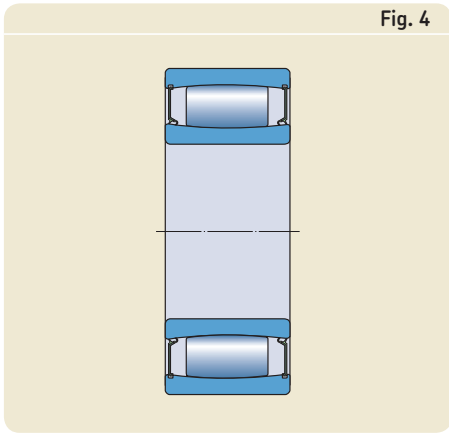

Sealed bearing
Lubricated for life and protected against contaminants, for heavy loads and low speeds

Availability

The product range is shown in the tables starting on **page 44**. SKF recommends checking availability of those bearings marked with a triangle. To do that, contact your local SKF representative or SKF distributor. The standard range is being continuously extended and the intention is to eventually manufacture all the bearings shown in the product tables.

Bearing benefits

Already well proven in service, toroidal roller bearings enable all types of machines and equipment to be

- smaller
- lighter
- more cost-effective
- more operationally reliable.

Replacing other bearings in a non-locating position with an equivalent CARB bearing can, depending on the application, improve performance and uptime while decreasing the need for maintenance. Why not put CARB bearings to the test and reap the benefits they can provide?



The CARB toroidal roller bearing – the cornerstone of the SKF self-aligning bearing system

The conventional solution

Conventional self-aligning bearing systems consist of two self-aligning ball bearings if there are high speeds and light loads, or two spherical roller bearings if there are heavy loads and moderate speeds. These simple bearing systems have good load carrying capacity and can accommodate misalignment as well as shaft deflections (→ **fig. 1**). However, they are not well suited to accommodate considerable axial expansion of the shaft.

In a conventional self-aligning bearing system, axial expansion of the shaft is accommodated by the bearing in the non-locating position. The fits for this bearing are selected to provide axial movement of one of the bearing rings, generally the outer ring, on its seat. This axial movement is accompanied by friction that induces axial loads in both bearings (→ **fig. 2**). In addition, the movement of the bearing with a loose fit on its seat can create damaging vibrations because the movement is “stick-slip” and not smooth (→ **diagram 1**).

This loose fit has a negative effect on the stiffness of the bearing arrangement. The bearing ring with the loose fit can also begin to “wander”, which wears the seat and leads to fretting corrosion which, if left unchecked, could “weld” the ring to its seat (→ **diagram 2**).

Conventional solution
Two spherical roller bearings (or self-aligning ball bearings) accommodate easily angular misalignment of the inner ring relative to the outer ring

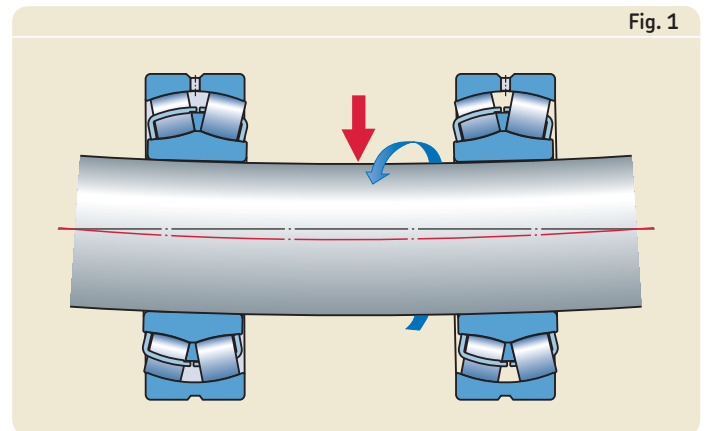

Fig. 1

Axial expansion of the shaft can induce an internal axial force on the bearing in the non-locating position and produce an axial force of equal magnitude on the bearing in the locating position and change the load distribution in the bearings

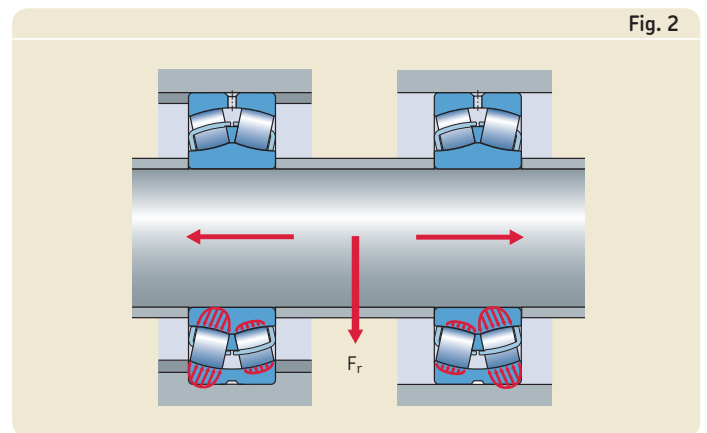

Fig. 2

Load conditions in a conventional solution

The axial expansion of the shaft can induce internal axial forces that change in magnitude due to the stick-slip effect of the moving outer ring of the non-locating bearing

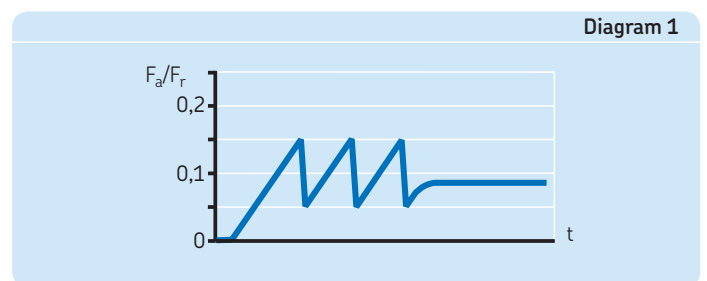

Diagram 1

When a non-locating bearing is prevented from moving in its seat, heavy axial forces are induced in the bearing arrangement that dramatically reduce the service life of the bearings

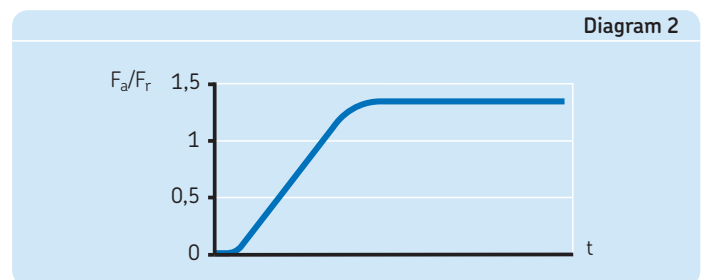

Diagram 2

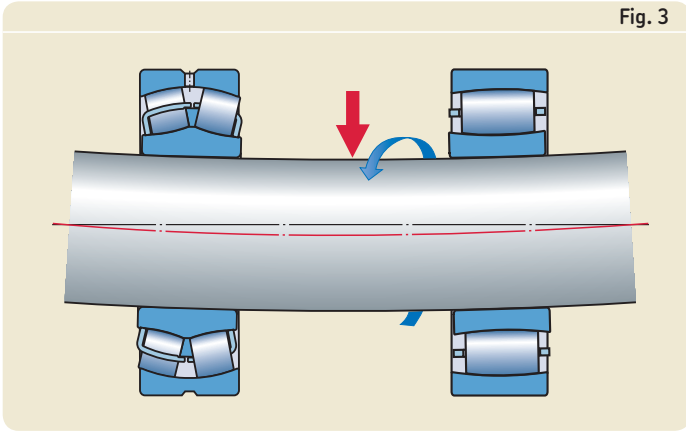

Fig. 3

The SKF solution
 With a spherical roller bearing or a self-aligning ball bearing in the locating position and a CARB toroidal roller bearing in the non-locating position, the system can accommodate misalignment and shaft deflections as well as thermal changes in shaft length, virtually without friction

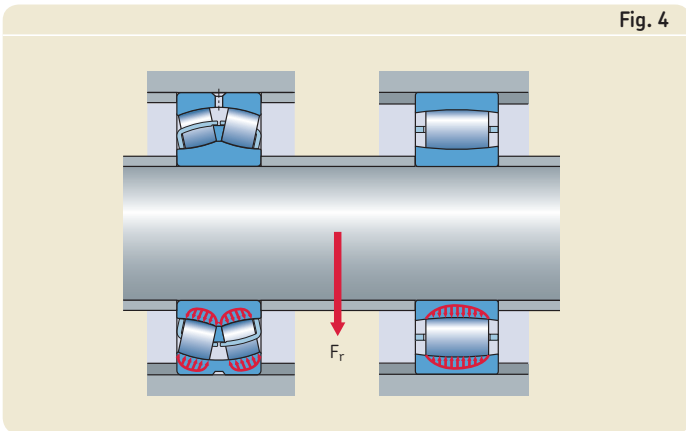

Fig. 4

There are no induced axial forces. Note that both the inner and outer rings of the CARB bearing are located axially and radially

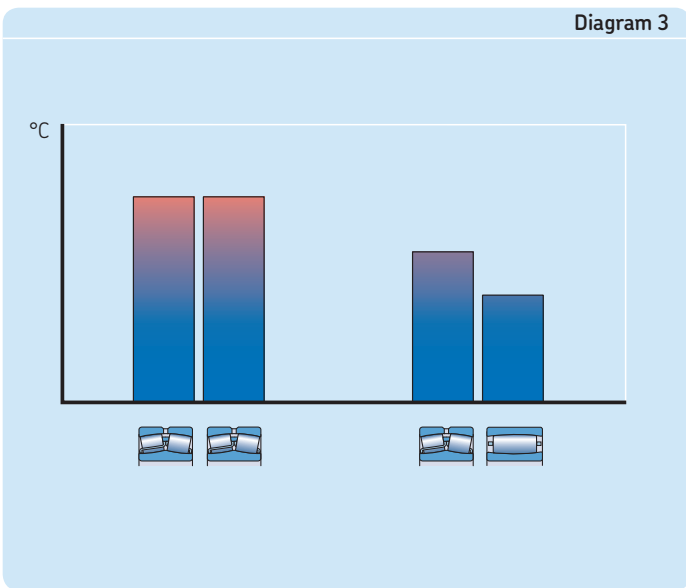

Diagram 3

Lower operating temperatures extend relubrication intervals and bearing service life

The SKF solution

There is no need for a compromise. The SKF self-aligning bearing system solves the problem by incorporating a CARB toroidal roller bearing in the non-locating position.

CARB toroidal roller bearings are able to accommodate misalignment and axial displacements within the bearing (→ fig. 3). This means that both rings of the non-locating bearing can be axially located in the housing and on the shaft (→ fig. 4). If it is necessary to secure the rings so that they cannot “creep”, they can be mounted with an interference fit, further enhancing the radial stiffness of the bearing arrangement.

This is an optimal solution for applications with undetermined load direction, e.g. vibrating applications, because internal preload and wear to the bearing seat in the housing are avoided. No longer is there a need to compromise between a tight fit and axial freedom.

A CARB toroidal roller bearing is designed to accommodate axial displacement without inducing additional axial internal forces or friction (→ fig. 4). This means that the loads acting on the bearing are determined exclusively by external radial and axial forces. Because of this, a bearing system incorporating a CARB bearing will have lower resultant loads and a better load distribution than a conventional bearing system. This also translates into lower operating temperatures, higher operating viscosities, extended relubrication intervals, and a significantly longer service life for both the bearings and the lubricant (→ diagram 3).

With a CARB toroidal roller bearing in the non-locating position, the many excellent design characteristics and properties of SKF spherical roller bearings and self-aligning ball bearings can be fully exploited. This provides new opportunities to further optimize machine design.

Successful in service

Although a rather recent invention, CARB toroidal roller bearings can be found in a variety of applications, spanning almost every industry. This bearing has already proven itself and in many cases has outperformed expectations by

- extending service life
- increasing reliability
- reducing maintenance
- enabling more compact designs.

One of the major application areas for CARB toroidal roller bearings is in steelmaking and particularly in continuous casters where the multitude of guide rollers are subjected to the most difficult operating conditions. Paper machines are another important application where shaft deflections and thermal changes in roll length of up to 10 mm have to be accommodated.

These main applications are not the only fields where CARB toroidal roller bearings perform successfully. They are also in service in large electric motors, wind power plants, water turbines, marine thrusters, crane wheels, separators, centrifuges, presses, staking machines for tanneries, rotary cultivators and mulchers.

Main application areas

- Steelmaking and rolling mills
- Conveyors and roller beds
- Paper machines
- Fans, blowers, pumps
- Crushers
- Gearboxes of all types
- Textile machines
- Food and beverage processing machines
- Agricultural machinery
- Vibrating screens

Major demands

- High operation reliability
- Long service life
- Reduced need of maintenance
- High load carrying capacity
- Lower operating costs
- Compact design
- Enhanced performance
- High power density

Solution

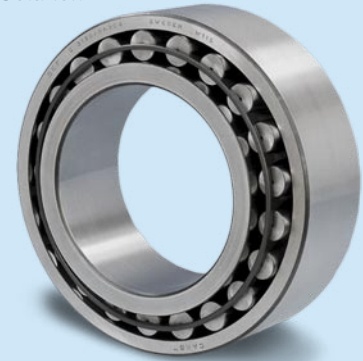

To facilitate the incorporation of CARB toroidal roller bearings in new as well as existing machines, please consult the SKF application engineering service.



A

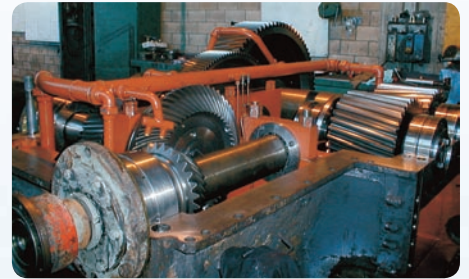

Selection of bearing size

To calculate bearing size or the basic rating life for a CARB toroidal roller bearing it is possible to use all the known and standardized (ISO 281) calculation methods. However, SKF recommends using the SKF rating life so that the enhanced performance characteristics of SKF bearings can be fully exploited. Detailed information can be found in the SKF General Catalogue in the section “Selection of bearing size” or in the “SKF Interactive Engineering Catalogue” available online at www.skf.com.

For a self-aligning bearing system that incorporates an SKF Explorer spherical roller bearing and a CARB bearing, system life can be calculated using the SKF system rating life equation:

$$L_{nm, Sys} = \sqrt[9/8]{\frac{1}{\frac{1}{L_{nm, SRB}^{9/8}} + \frac{1}{L_{nm, CARB}^{9/8}}}}$$

where

$L_{nm, Sys}$ = SKF rating life for the bearing system (at $100 - n^1$ % reliability), millions of revolutions

$L_{nm, SRB}$ = SKF rating life for the locating spherical roller bearing (at $100 - n^1$ % reliability), millions of revolutions

$L_{nm, CARB}$ = SKF rating life for the non-locating CARB toroidal roller bearing (at $100 - n^1$ % reliability), millions of revolutions.

Longer life or downsizing

When used in a self-aligning bearing system, the CARB bearing prevents internally induced axial forces from occurring. This is in contrast to conventional self-aligning bearing systems with two spherical roller bearings or self-aligning ball bearings, where the induced internal axial forces can be 20 % or more of the radial load acting on the non-locating bearing. These additional forces represent a sizeable percentage of the total load and can result in premature bearing failure unless larger bearings are used to compensate for the additional loads.

Because a CARB toroidal roller bearing prevents internally induced axial forces from occurring, the load conditions in the bearing system can be predicted accurately. The locating bearing is only subjected to its portion of the external radial and axial loads, while the non-locating bearing is only subjected to its portion of the radial load.

Whether a spherical roller bearing (→ **diagram 1**) or a self-aligning ball bearing (→ **diagram 2**) is used in the locating position, the SKF self-aligning bearing system can substantially increase the service life of the bearing arrangement. It also worth noting that even if smaller bearings are used, the SKF self-aligning bearing system will often achieve a longer system life than a conventional system using larger bearings. This can be exploited by downsizing adjacent components and reducing costs.

To take full advantage of the benefits offered by the SKF self-aligning bearing system, the size of both the locating and non-locating bearings must be selected carefully. For assistance, contact the SKF application engineering service.

¹⁾ The factor n represents the difference between the requisite reliability and 100 %

Compare the life of a conventional self-aligning bearing system using two spherical roller bearings with a bearing system that uses a CARB toroidal roller bearing and a spherical roller bearing

Diagram 1

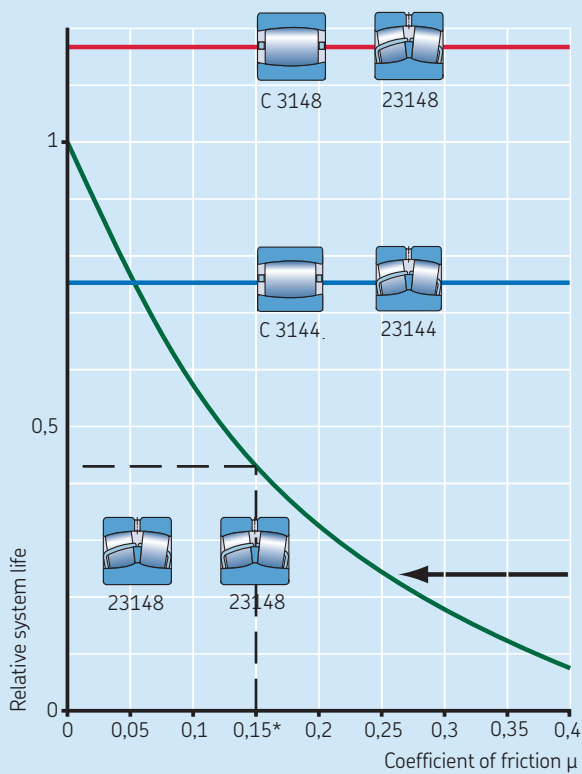

* Typical value for steel on cast iron

Compare the life of a conventional self-aligning bearing system using two self-aligning ball bearings with a bearing system that uses a CARB toroidal roller bearing and a self-aligning ball bearing

Diagram 2

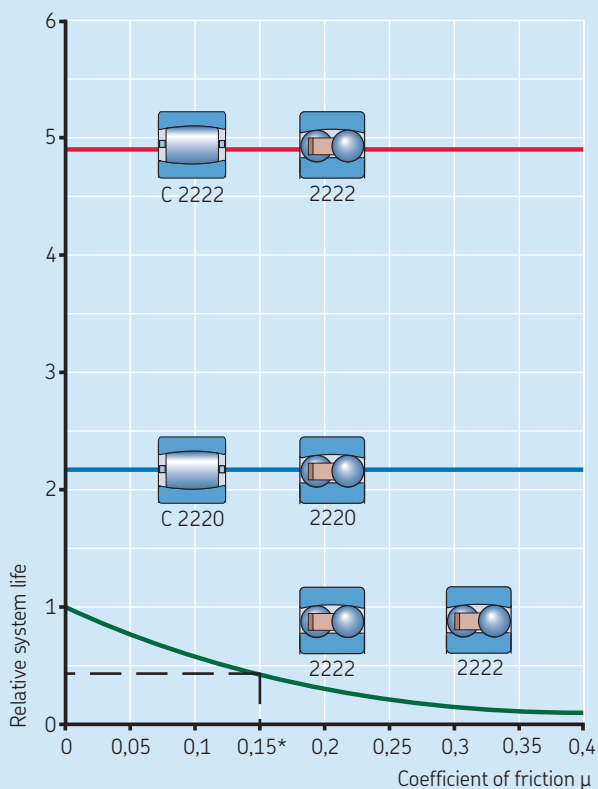

* Typical value for steel on cast iron

Design of bearing arrangements

Two bearings are generally required to support, guide and locate a shaft in the radial and axial directions. To do this, one bearing is designated the locating bearing and the other is the non-locating bearing.

In traditional self-aligning bearing systems, the locating bearing is secured in its housing and locates the shaft axially, while the non-locating bearing typically moves in its housing to accommodate axial expansion of the shaft.

With the SKF self-aligning bearing system, a CARB toroidal roller bearing is used in the non-locating position and either a spherical roller bearing (→ **fig. 1**) or a self-aligning ball bearing (→ **fig. 2**) is used in the locating position. Because a CARB bearing can accommodate axial expansion internally like a cylindrical roller bearing, it prevents internally induced axial forces from occurring; these forces would otherwise be present if the bearing had to slide on its seat in the housing. The ability to accommodate axial shaft expansion internally enables the bearing rings to be axially located on the shaft and in the housing.

Radial location

To take advantage of the very high load carrying capacity and full life potential of a toroidal roller bearing, the bearing rings must be fully supported around their whole circumference and across the full width of the outer ring.

Selecting the proper fit

To locate a shaft radially, most applications require an interference fit between the bearing rings and their seats. However, if easy mounting and/or dismounting are required, a looser outer ring fit might be applied.

Recommendations for suitable tolerances for the shaft diameter and housing bore for CARB toroidal roller bearings are provided in **tables 1, 2** and **3**. These recommendations apply to solid steel shafts and housings made from cast iron or steel.

Generally, CARB toroidal roller bearings follow the fit recommendations for spherical roller bearings on shafts and in housings. However, a spherical roller bearing in the non-locating position must be axially free, which requires a loose housing fit – this is not necessary for bearing arrangements using a CARB toroidal roller bearing. CARB bearings

(and spherical roller bearings in the locating position) can therefore utilize the advantages of tight outer ring fits. For example, for a fan that might have an unbalanced fan rotor, a K7 fit is applied for a split housing and P7 for a non-split housing.

For normal, stationary outer ring load it might not be necessary to have a tight outer ring fit.

Bearings with a tapered bore are mounted either directly on a tapered journal or on an adapter or a withdrawal sleeve on cylindrical shaft seats. The fit of the inner ring in these cases depends on how far the ring is driven up the tapered seat.

Accuracy of associated components

The accuracy of the cylindrical seats on the shaft and in the housing bore should correspond to that of the bearing. For CARB toroidal roller bearings the shaft seat should be tolerance grade 6 and the housing seat grade 7. For an adapter or withdrawal sleeve, wider diameter tolerances can be adopted for the cylindrical seat on the shaft, e.g. grade 9 or 10.

The cylindricity as defined in ISO 1101-1996 for the bearing seat should be 1 or 2 grades

SKF self-aligning bearing system with a spherical roller bearing in the locating position and a CARB toroidal roller bearing in the non-locating position

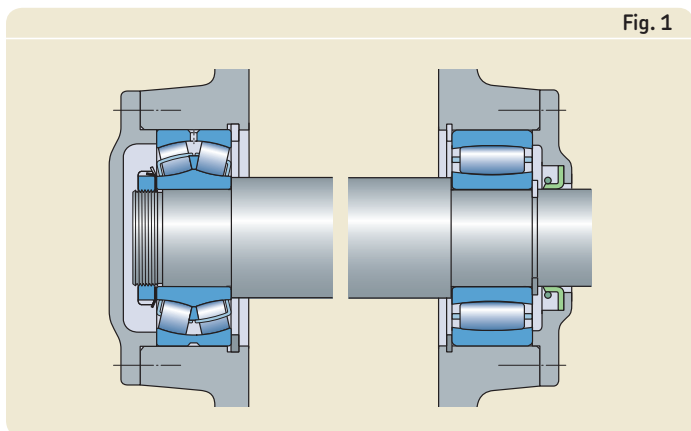

Fig. 1

SKF self-aligning bearing system with a self-aligning ball bearing in the locating position and a CARB toroidal roller bearing in the non-locating position

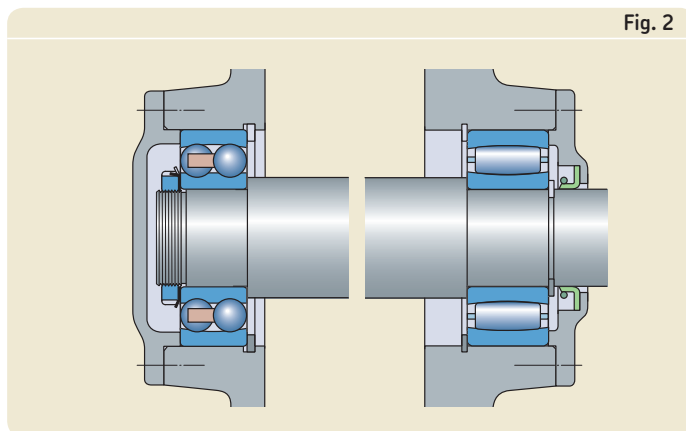

Fig. 2

better than the recommended dimensional tolerance depending on the requirements. For example, a shaft seat machined to tolerance p6 should have a cylindricity grade 5 or 4.

Table 1

Fits for solid steel shafts				
Conditions	Examples	Shaft diameter (mm)		Tolerance
		over	incl.	
Bearings with a cylindrical bore Rotating inner ring load or direction of load indeterminate				
Normal to heavy loads (P > 0,05 C)	General bearing applications, electric motors, turbines, pumps, gearboxes, transmissions, woodworking machines, wind turbines	25	25	m5
		40	40	m5
		60	60	n5 ¹⁾
		100	100	n6 ¹⁾
		200	200	p6 ²⁾
		500	500	r6 ¹⁾ r7 ¹⁾
Very heavy loads or shock loads with difficult working conditions (P > 0,1 C)	Traction motors, rolling mills	50	70	n5 ¹⁾
		70	140	p6 ²⁾
		140	280	r6 ¹⁾
		280	400	s6 _{min} ± IT6/2 ³⁾⁴⁾ s7 _{min} ± IT7/2 ³⁾⁴⁾
Bearings with a tapered bore on an adapter or withdrawal sleeve Normal loads and/or normal speeds Heavy loads and/or high speeds				h10/IT7/2 h9/IT5/2
Stationary inner ring load Easy dismounting unnecessary Easy dismounting desirable				h6 g6 ⁵⁾
¹⁾ Bearings with radial internal clearance greater than Normal may be necessary ²⁾ Bearings with radial internal clearance greater than Normal are recommended for d ≤ 150 mm. For d > 150 mm bearings with radial internal clearance greater than Normal may be necessary ³⁾ Bearings with radial internal clearance greater than Normal are recommended ⁴⁾ For tolerance values please consult the SKF Interactive Engineering Catalogue online at www.skf.com or the SKF application engineering service ⁵⁾ Tolerance f6 can be selected for large bearings to provide easy dismounting				

Table 2

Fits for non-split cast iron and steel housings			
Conditions	Examples	Tolerance	Remarks
Rotating outer ring load Heavy loads and shock loads	Crushers, vibrating screens	N6	Bearing outside diameter < 160 mm Bearing outside diameter ≥ 160 mm
		P6	
Stationary outer ring load Loads of all kinds	General engineering	H7	
Direction of load indeterminate Heavy shock loads		M7	
Normal to heavy loads (P > 0,05 C)	General engineering, electric motors, pumps, fans	K7	Easy mounting of bearing required
		H7	

Table 3

Fits for split cast iron and steel housings		
Conditions	Examples	Tolerance
Stationary outer ring load Loads of all kinds	General engineering	H7
Direction of load indeterminate Loads of all kinds	General engineering, electric motors, pumps	J7

Axial location

The rings of CARB toroidal roller bearings should be axially located on both sides on the shaft as well as in the housing. SKF recommends arranging the bearing rings so that they abut a shoulder on the shaft or in the housing. Inner rings can be locked in position using either

- a lock nut (→ **fig. 3**)
- a retaining ring (→ **fig. 4**)
- an end plate screwed to the shaft end (→ **fig. 5**).

Outer rings are usually positioned and secured in the housing by an end cover (→ **fig. 6**).

Instead of integral shaft and housing shoulders CARB toroidal roller bearings can be mounted against either

- spacer sleeves (→ **fig. 7**)
- retaining rings (→ **fig. 8**).

Bearings with a tapered bore that are mounted either

- directly onto a tapered seat are usually secured to the shaft with a nut on the threaded section (→ **fig. 9**)
- on an adapter sleeve and a stepped shaft are secured against a spacer ring (→ **fig. 10**)
- on a withdrawal sleeve against a shaft shoulder are secured by a shaft nut (→ **fig. 11**) or an end plate (→ **fig. 12**).

Abutment and fillet dimensions

The abutment and fillet dimensions, which include the diameters of shaft and housing shoulders, spacer sleeves etc. have been determined so that adequate abutment surfaces are provided for the side faces of the bearing rings without any danger of the rotating parts being fouled. The recommended abutment and fillet dimensions for each individual bearing can be found in the product tables.

Inner ring located axially with a lock nut

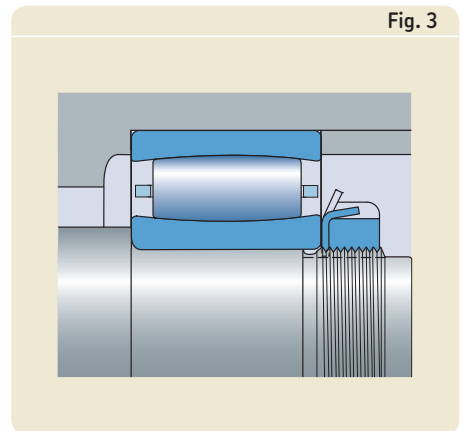

Inner ring located axially with a retaining ring

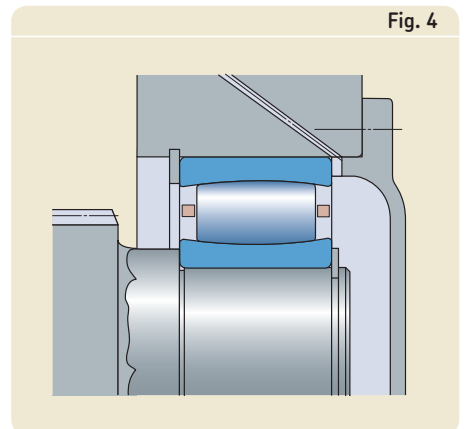

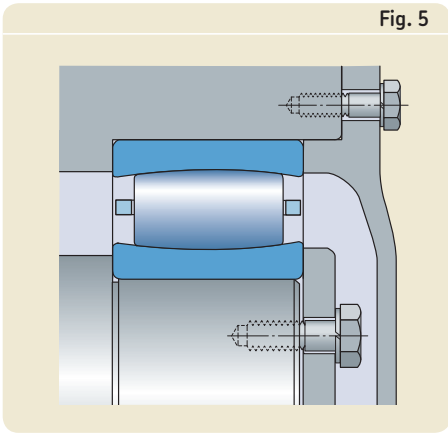

Fig. 5

Inner ring located axially with an end plate

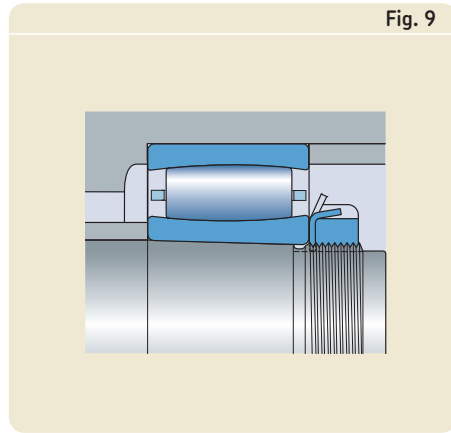

Fig. 9

Inner ring on a tapered seat held in place by a shaft nut

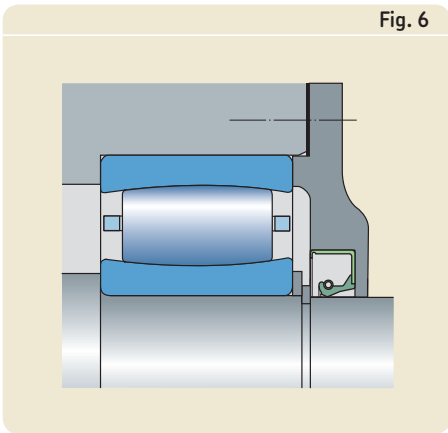

Fig. 6

Outer ring located axially with an end cover

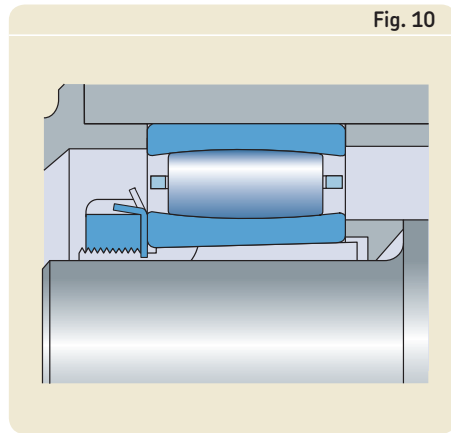

Fig. 10

Inner ring on an adapter sleeve and a stepped shaft, axially located against a spacer ring

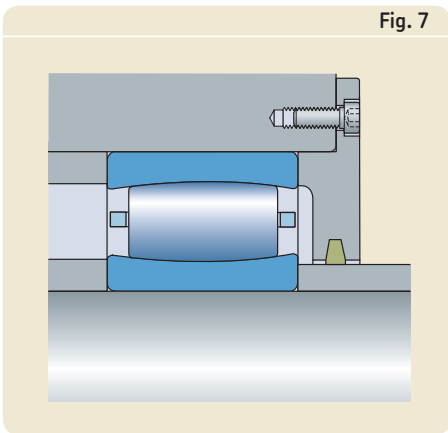

Fig. 7

Spacer sleeves used to axially locate the inner and outer rings

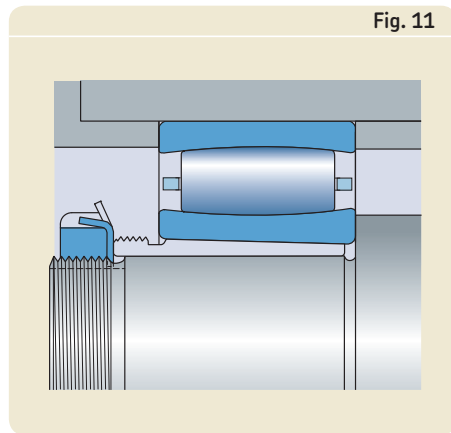

Fig. 11

Inner ring on a withdrawal sleeve and a stepped shaft, axially located by a shaft nut

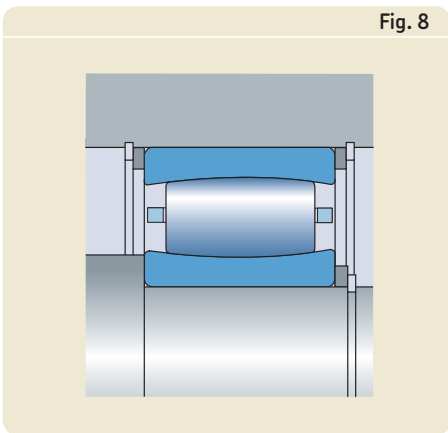

Fig. 8

Retaining rings used to axially locate the bearing rings

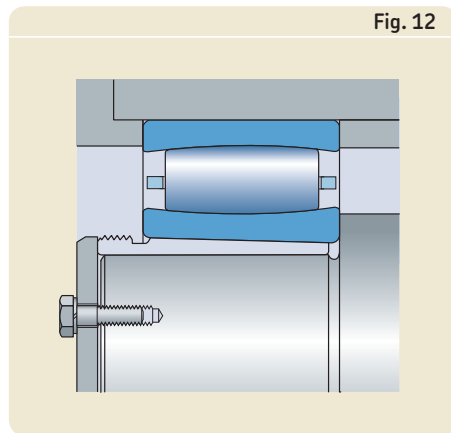

Fig. 12

Inner ring on a withdrawal sleeve and a stepped shaft, axially located by an end plate

Design of adjacent components

Space on the sides of the bearing

To enable axial displacement of the shaft relative to the housing, space must be provided on both sides of the bearing as indicated in **fig. 13**. The actual value for the width of this space can be estimated based on

- the value C_a (from the product tables)
- the axial displacement of the bearing rings from the central position expected in operation
- the displacement of the rings caused by misalignment

$$C_{\text{areq}} = C_a + 0,5 (s + s_{\text{mis}})$$

or

$$C_{\text{areq}} = C_a + 0,5 (s + k_1 B \alpha)$$

where

C_{areq} = width of the space required on each side of the bearing, mm

C_a = minimum width of the space required on each side of the bearing, mm (→ product tables)

s = relative axial displacement of the rings, thermal change in shaft length, mm

s_{mis} = axial displacement of the roller complement caused by misalignment, mm

k_1 = misalignment factor (→ product tables)

B = bearing width, mm (→ product tables)

α = misalignment, degrees

See also under "Axial displacement" starting on **page 40**.

Normally, the bearing rings are mounted so that they are not displaced relative to each other. However, if considerable thermal changes in shaft length can be expected, the inner ring can be mounted offset relative to the outer ring up to the permissible axial displacement s_1 or s_2 in the direction opposite to the expected thermal elongation (→ **fig. 14**). In this way, the permissible axial displacement can be appreciably extended, an advantage which is made use of in the bearing arrangement of drying cylinders in papermaking machines.

When designing large bearing arrangements, it is particularly important to take steps so that mounting and dismounting of the bearings are facilitated or actually made possible.

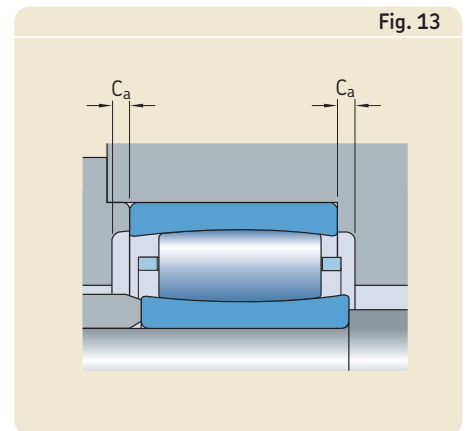

Free axial space on both sides of the bearing

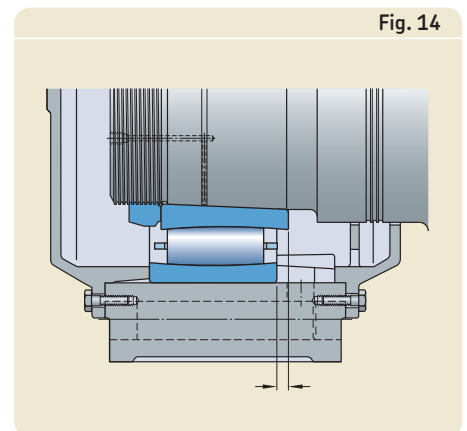

The permissible axial displacement can be extended by mounting the outer ring purposely displaced relative to the inner ring

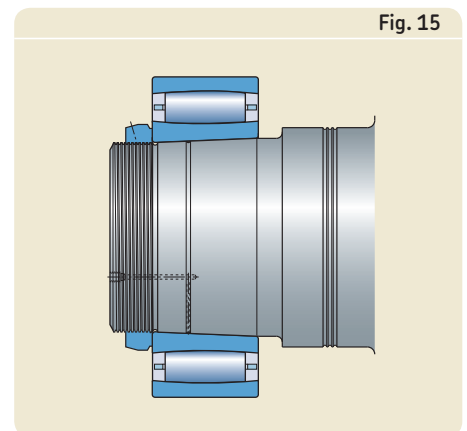

A CARB toroidal roller bearing on a tapered seat with an oil duct and distributor groove

Oil ducts and distributor grooves for the oil injection method

If the oil injection method is to be used

- for mounting and/or dismounting bearings on tapered seats (→ fig. 15)
- for dismounting bearings on cylindrical seats
- for dismounting bearings in housings

it is necessary to provide oil ducts and distributor grooves in the seat on the shaft or in the housing. The distance of the distributor groove from the side at which the bearing is to be mounted and/or dismounted should correspond to approximately a third of the bearing width. For wide bearings on cylindrical seats it is recommended to use two distributor grooves. One groove at one sixth

and the other one two thirds from the side at which the bearing is to be mounted and/or dismounted. Recommended dimensions for the oil ducts, distributor grooves and appropriate threads for the connections are provided in **tables 4** and **5**.

Table 4

Recommended dimensions for oil ducts and distributor grooves

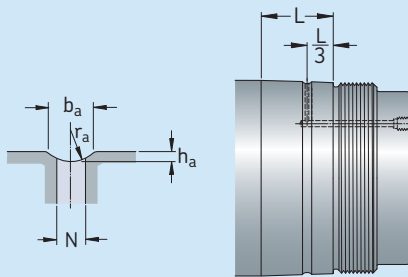

Bearing seat diameter		Dimensions		r_a	N
over	incl.	b_a	h_a		
mm		mm			
100	100	3	0,5	2,5	2,5
150	150	4	0,8	3	3
200	200	4	0,8	3	3
200	250	5	1	4	4
250	300	5	1	4	4
300	400	6	1,25	4,5	5
400	500	7	1,5	5	5
500	650	8	1,5	6	6
650	800	10	2	7	7
800	1 000	12	2,5	8	8

Table 5

Threaded connection holes

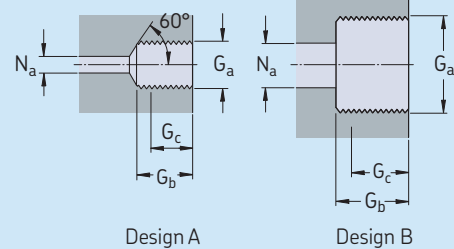

Thread	Design	Dimensions		N_a
G_a		G_b	$G_c^{1)}$	max
mm	–	mm		
M 6	A	10	8	3
G 1/8	A	12	10	3
G 1/4	A	15	12	5
G 3/8	B	15	12	8
G 1/2	B	18	14	8
G 3/4	B	20	16	8

¹⁾ Effective threaded length

Sealing the bearing arrangement

When selecting the most suitable sealing solution for a self-aligning bearing arrangement pay particular attention to

- the angular misalignment of the shaft
- the magnitude of axial displacement.

More information about general selection criteria can be found in the section “Sealing arrangements” in the SKF General Catalogue or in the “SKF Interactive Engineering Catalogue” online at www.skf.com.

A non-contact sealing arrangement should be used when the operating conditions involve

- high speeds
- large axial displacements
- high temperatures

and the sealing position is not directly exposed to contamination. The shaft should be horizontal.

A simple gap-type seal (→ **fig. 16**) is suitable for sealing the non-locating bearing in a self-aligning bearing system. The size of the gap can be adapted to the shaft misalignment and is not limited in any way.

Single or multi-stage labyrinth seals are obviously more efficient than the simple gap-type seal, but are more expensive. With CARB toroidal roller bearings, the labyrinth passages should be arranged axially so that the shaft can move axially during operation (→ **fig. 17**). If considerable misalignment is expected in operation, the size of the gaps should be adjusted accordingly. When split housings are used, labyrinth seals with radially arranged passages can be used, provided axial movement of the shaft relative to the housing is not limited (→ **fig. 18**).

Radial shaft seals are contact seals that are suitable for sealing greased or oil lubricated CARB toroidal roller bearings, provided misalignment is small and the seal lip counterface is sufficiently wide (→ **fig. 19**).

Some seal types are supplied as standard with SKF bearing housings and include a double-lip contact seal, a labyrinth seal or a Taconite seal (→ **fig. 20**). Additional information can be found in the SKF brochures 6112 “SNL plummer block housings solve the housing problems” and 6101 “SNL 30, SNL 31 and SNL 32 solve the housing problems”.

Reference

Additional information about radial shaft seals, V-ring seals or mechanical seals can be found in the SKF catalogue “Industrial shaft seals” or in the “SKF Interactive Engineering Catalogue” online at www.skf.com.



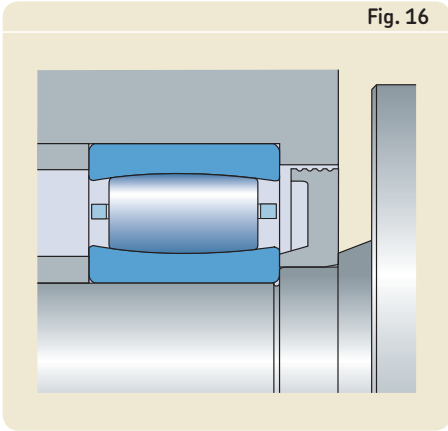

Fig. 16

Gap-type seal

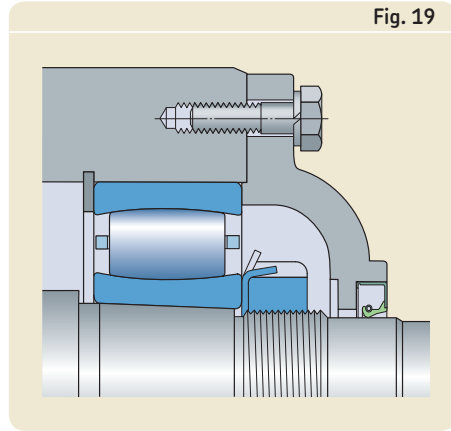

Fig. 19

Radial shaft seal

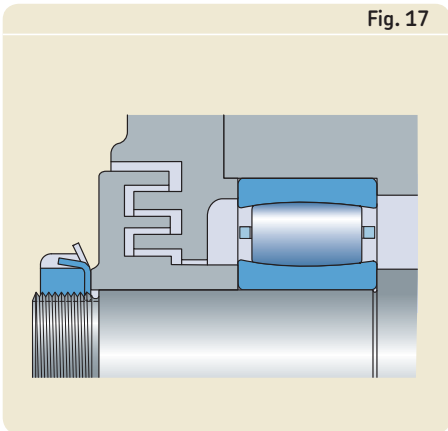

Fig. 17

Labyrinth seal with axially arranged passages

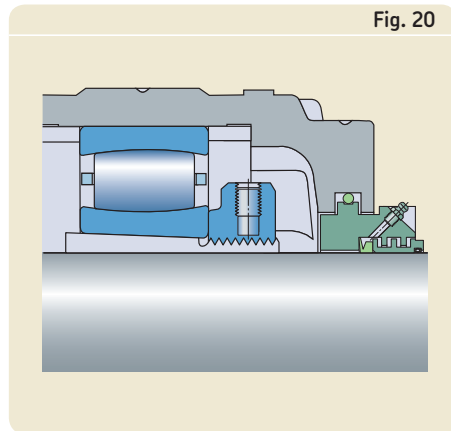

Fig. 20

Taconite seal

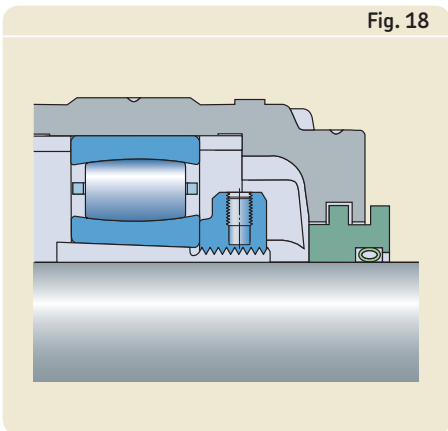

Fig. 18

Labyrinth seal with radially arranged passages

Lubrication

CARB toroidal roller bearings can be lubricated with grease as well as oil. There is no strict rule for when grease or oil should be used.

Grease has distinct advantages over oil. It is more easily retained in the bearing, and is less likely to leak if the shaft is at an angle or arranged vertically.

On the other hand, oil enables higher operating speeds and dissipates heat more effectively than grease. This is particularly important when an external heat source can impact operating temperatures.

The lubricant is supplied to the CARB bearing via a grease fitting to a duct that opens immediately adjacent to the side face of the outer ring. To enable the used grease to be purged from the bearing and housing, there should be a grease escape hole at the opposite side of the housing. If the housing has no escape hole (or that hole is plugged) this could damage the seals (→ fig. 1).

Grease supply and grease escape hole

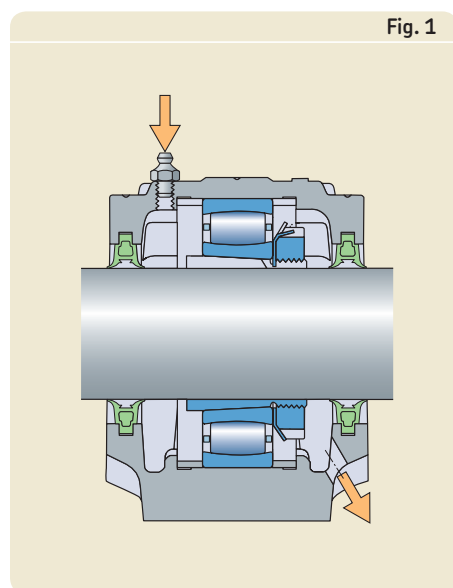

Grease lubrication

To lubricate CARB toroidal roller bearings, good quality rust inhibiting greases that are resistant to ageing and have a consistency of 2 or 3 are suitable. Many factors influence the choice of grease. To assist in this process, SKF greases that are suitable for CARB bearing lubrication are listed in **table 1**.

The right quantity of grease

For the majority of applications the following guidelines apply:

- Caged CARB toroidal roller bearings should be filled with grease to approximately 50 %. In bearings that are to be greased before mounting it is recommended just to fill the space between the inner ring and the cage (→ fig. 2).
- Full complement CARB toroidal roller bearings should be completely filled with grease.
- The free space in the bearing housing should be filled with grease to between 30 and 50 %.

For bearings that turn slowly but where good protection against corrosion is required, all the free space in the housing can be filled with grease as there is little risk that the operating temperature will increase.

Table 1

Recommended SKF greases	Operating conditions	SKF grease Designation	Temperature range ¹⁾	Viscosity at 40/100 °C
	–	–	°C (F°)	mm ² /s
	Standard bearing arrangements	LGMT 2	–30/+120 (–20/+250)	110/11
	Standard bearing arrangements but with relatively high ambient temperatures	LGMT 3	–30/+120 (–20/+250)	125/12
	Operating temperatures always over 100 °C	LGHB 2	–20/+150 (–5/+300)	420/26,5
	High operating temperatures, smooth operation	LGHP 2	–40/+150 (–40/+300)	96/10,5
	Shock loads, heavy loads, vibrations	LGEP 2	–20/+110 (–5/+230)	200/16
	High demands on environmental friendliness	LGGB 2	–40/+120 (–40/+250)	110/13

¹⁾ For safe bearing operating temperatures where the grease will function reliably, → the SKF General Catalogue 6000, section "Temperature range – the SKF traffic light concept", starting on **page 232**

More details about SKF greases can be found in
 – SKF catalogue MP3000 "SKF Maintenance and Lubrication Products" or online at www.mapro.skf.com
 – "SKF Interactive Engineering Catalogue" online at www.skf.com

Table 2

Bearing design	Bearing factor b_f	Recommended limits for the speed factor A for a load ratio		
		$C/P \geq 15$	$C/P \approx 8$	$C/P \approx 4$
–	–	mm/min		
CARB bearings with a cage	2	350 000	200 000	100 000
CARB bearings – full complement ¹⁾	4	N.A. ³⁾	N.A. ³⁾	20 000 ²⁾

¹⁾ The t_f value obtained from **diagram 1** needs to be divided by a factor of 10
²⁾ For higher speeds oil lubrication is recommended
³⁾ For these C/P values a caged bearing is recommended

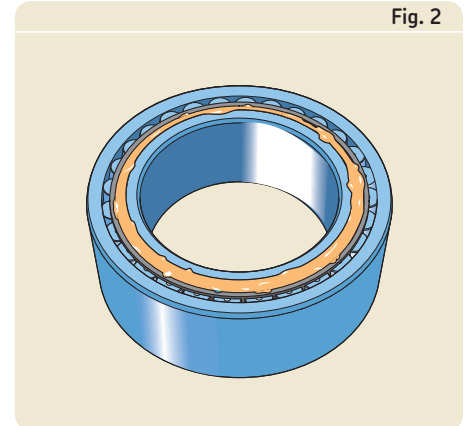

Bearing grease fill

Caged CARB toroidal roller bearings should not be completely filled with grease; for high speed operation fill only the space between the inner ring and the cage

Relubrication

CARB toroidal roller bearings have to be relubricated if the service life of the grease is shorter than the expected service life of the bearing. Relubrication should always be undertaken at a time when the condition of the existing lubricant is still satisfactory.

There are a number of factors that determine relubrication intervals. These include bearing type and size, speed, operating temperature, grease type, space around the bearing and the bearing environment.

It is only possible to base recommendations on statistical rules; the SKF relubrication intervals are defined as the time period, at the end of which 99 % of the bearings are still reliably lubricated. This represents L_1 for grease life.

SKF recommends using experience data from running applications and tests, together with the estimated relubrication intervals provided in the next section.

Relubrication intervals

The relubrication intervals t_f for CARB bearings on horizontal shafts under normal and clean conditions can be obtained from **diagram 1** as a function of

- the speed factor A, where

$$A = n d_m$$

$$n = \text{rotational speed, r/min}$$

$$d_m = \text{bearing mean diameter} = 0,5 (d + D), \text{ mm}$$
- the bearing factor b_f depending on bearing design (\rightarrow **table 2**)
- the load ratio C/P.

The relubrication interval t_f is an estimated value, valid for an operating temperature of 70 °C, using a mineral oil based grease with a good quality lithium thickener. When bearing operating conditions differ, adjust the

relubrication intervals obtained from **diagram 1** according to the information provided in the following section “Deviating conditions”.

If the speed factor A exceeds a value of 70 % of the recommended limits according to **table 2**, or if ambient temperatures are high, use the calculations presented in the SKF General Catalogue, section “Speeds and vibration”, to check the operating temperature and whether the lubrication system is appropriate.

Diagram 1

Relubrication intervals for CARB toroidal roller bearings at 70 °C

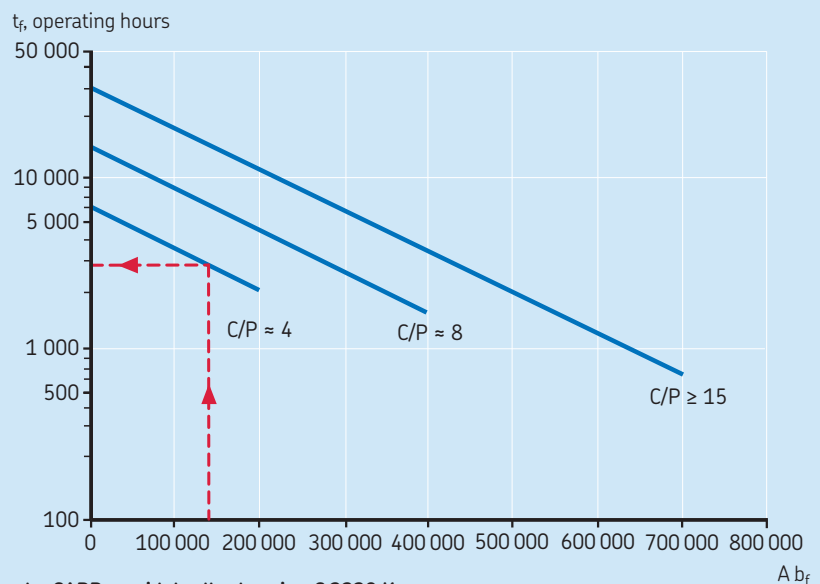

Example: CARB toroidal roller bearing C 2220 K

The bearing has a bore diameter $d = 100$ mm, an outside diameter $D = 180$ mm and rotates at a speed $n = 500$ r/min. The load ratio C/P is 4 and the operating temperature lies between 60 and 70 °C (140 and 160 °F). What is the relubrication interval?

The factor $A b_f$ is obtained as follows: $n d_m b_f = n 0,5 (d + D) b_f = 500 \times 0,5 (100 + 180) \times 2 = 140 000$. Follow a vertical line from the x-axis from the point $A b_f = 140 000$ until it intersects the line of the load ratio C/P = 4. The relubrication interval can then be read off on the y-axis by drawing a horizontal line from the point of intersection with 3 000 operating hours.

Deviating conditions

Operating temperature

To account for the accelerated ageing of grease in hot running applications, SKF recommends halving the intervals obtained from **diagram 1** for every 15 °C increase in bearing temperature above 70 °C.

The relubrication interval t_f may be extended at temperatures below 70 °C, provided the operating temperature does not exceed a certain limit that depends on the grease used. Extending the relubrication interval t_f by more than a factor of two is not recommended.

For full complement bearings, t_f values obtained from **diagram 1** should not be prolonged.

Moreover, it is not advisable to use relubrication intervals in excess of 30 000 hours.

For many applications, there are practical grease lubrication limits, when the bearing ring with the highest temperature reaches an operating temperature of 100 °C (210 °F). Above this temperature special greases should be used. In addition, temperature stability of the bearing and premature seal failure should be taken into consideration.

For high temperature applications, contact the SKF application engineering service.

Very light loads

In many cases the relubrication interval may be prolonged if loads are light ($C/P = 30$ to 50). In order to provide satisfactory operation, CARB bearings must always be subjected to a given minimum load (→ “Minimum load” on **page 42**).

Vertical shafts

For bearings on vertical shafts, the relubrication intervals obtained from **diagram 1** should be halved. The use of a good seal or retaining shield is a prerequisite or grease can leak from the bearing arrangement.

Vibrations

Mild vibrations do not have a negative effect on grease life, but high vibration levels and shock loads, such as those in vibrating screen applications, can cause the grease to churn. In these cases the relubrication interval should be reduced. If the grease becomes too soft, a grease with a better mechanical stability (e.g. LGHB 2) and/or a stiffer grease (NLGI 3) should be used.

Outer ring rotation

In applications where there is outer ring rotation, the value of $n d_m$ is calculated by applying the value of the bearing outside diameter D instead of d_m . The use of a good sealing mechanism is a prerequisite in order to avoid grease loss.

In applications where there are high outer ring speeds (i.e. > 50 % of the reference speed rating in the product tables), greases with a reduced bleeding tendency should be selected (e.g. lithium complex and polyurea).

Contamination

In case of ingress of contaminants, more frequent relubrication can reduce the negative effects of foreign particles on the bleeding characteristics of grease while reducing the damaging effects caused by overrolling of particles. Fluid contaminants (water, process fluids) also call for a reduced lubrication interval. In case of severe contamination, continuous relubrication should be considered.

Grease valve

Excess grease can leave the housing through a grease escape valve

Fig. 3

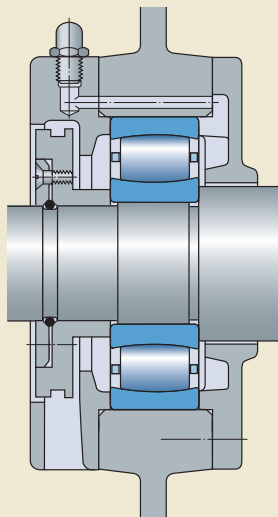

Supplying grease to a CARB bearing

When using a hand-operated grease gun, excessive pressure should be avoided or the seals may be damaged

Fig. 4

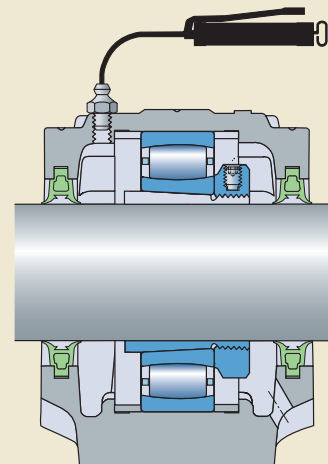

Requisite grease quantities for relubrication

The used grease in a CARB toroidal roller bearing should be replaced by fresh grease. The quantity of grease required for this depends on the bearing size; this can be determined using

$$G_p = 0,005 D B$$

where

G_p = grease quantity required for periodic lubrication, g

D = bearing outside diameter, mm

B = bearing width, mm

Grease escape valve

If CARB toroidal roller bearings are relubricated frequently, there is a risk that too much grease will collect in the housing. This risk can be avoided by using a grease escape valve that enables excess grease to leave the housing (→ fig. 3).

A grease escape valve consists of a washer that rotates with the shaft and forms a narrow gap to the housing cover. Excess grease is carried by the washer into this gap and leaves the housing by a grease escape hole in the base.

SKF SNL housings can be supplied with a grease escape hole (designation suffix V).

The grease should always be supplied to the side of the bearing opposite the grease escape valve so that it is forced to pass through the bearing. When the bearing is mounted on an adapter sleeve, the lock nut functions in the same way as the disc in a grease escape valve. Therefore, the lock nut and grease escape valve should be positioned on the same side, while the grease fitting needs to be positioned on the opposite side (→ fig. 4).

Oil lubrication

Oil lubrication is recommended or must be used if

- the relubrication intervals for grease are too short
- speeds and/or operating temperatures are too high for grease
- heat must be removed from the bearing position
- adjacent components are lubricated with oil.

For CARB toroidal roller bearings the following methods are normally employed:

- Oil bath lubrication where the oil is distributed by rotating machine components to the bearing arrangement and runs back to the sump.

- Circulating oil lubrication where the circulation is achieved by the aid of a pump. After the oil has passed through the bearing, it generally settles in a tank. Before supplying the oil again to the bearing it is cooled and/or filtered, if needed. The use of this method requires efficient sealing to prevent oil leakage.

The oil level should be checked regularly. The appropriate level should not be higher than the middle of the lowest roller when the bearing is stationary.

The lower limit should be 2 to 3 mm above the lowest point of the outer ring smallest diameter, D_1 in the product tables (→ fig. 5).

The same oils can be used for lubricating CARB toroidal roller bearings as for spherical and cylindrical roller bearings. They should

- have good thermal and chemical stability
- contain anti-wear additives
- provide good protection against corrosion.

Oils of viscosity class

- ISO VG 150 or ISO VG 220 can be used under normal conditions
- ISO VG 320 or VG 460 may be more appropriate at high temperatures, under heavy loads and slow speeds.

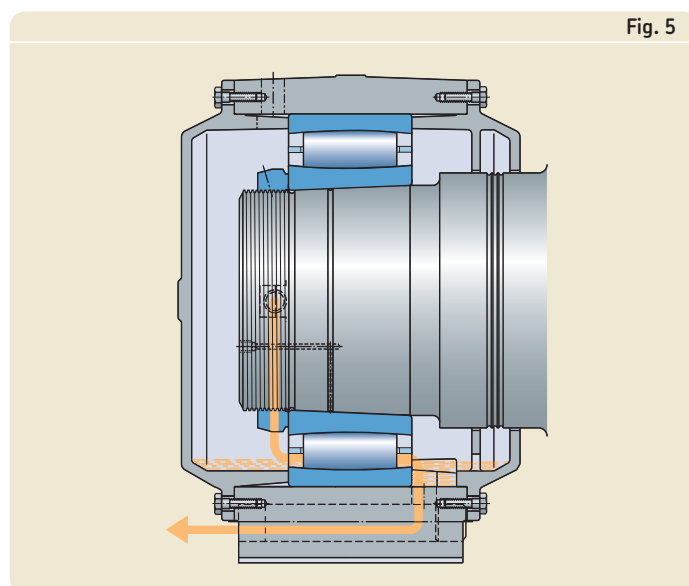

Fig. 5

Oil level in CARB toroidal roller bearing arrangements

Max.: middle of the lowest roller

Min.: 2 to 3 mm above the lowest point of the outer ring smallest diameter, D_1 in the product tables

Mounting

A variety of mechanical and hydraulic tools and heaters can be used to mount a CARB bearing. The one basic rule in any installation procedure is to avoid hitting the bearing rings, the rollers or cage. In all cases, before mounting, the rust inhibiting oil should be wiped from the bore and outside diameter of new bearings and sleeves (if applicable). The shaft seat and outside diameter of the sleeve (if applicable) should be coated with a thin layer of light oil.

When mounting a CARB bearing onto a shaft or in a housing, both bearing rings and the roller complement must be centred relative to each other. For this reason SKF recommends mounting CARB bearings when the shaft or housing is in the horizontal position.

When mounting a CARB bearing onto a vertical shaft or into a vertical housing, the roller complement together with the inner or outer ring will move downwards until all clearance has been removed. Unless proper clearance is maintained during and after installation, the expansion or compression forces resulting from an interference fit on either the inner or outer ring will create a preload. This preload can cause indentations in the raceways and/or prevent the bearing from turning altogether. To prevent this preload condition from occurring during vertical mounting, a bearing handling tool, which keeps the bearing components centred, should be used.

Detailed information on mounting rolling bearings can be found in the publication "SKF Bearing Maintenance Handbook", as well as online at www.skf.com/mount.

Mounting on a cylindrical seat

With CARB bearings, the ring that is to have the tighter fit should be mounted first. If the bearing is to be cold mounted on the shaft and in the housing at the same time, a tool of the type shown in **fig. 1** should be used. This tool abuts both bearing rings to apply even pressure without damaging the rolling elements or raceways.

As a rule, larger bearings cannot be cold mounted, as the force required to press a bearing into position increases considerably with its size. Therefore it is recommended

- to heat the bearing before it is mounted on the shaft
- to heat non-split housings before inserting the bearing.

To mount a bearing on the shaft, a temperature differential of 80 °C (175 °F) between ambient temperature and heated

inner ring is usually sufficient. For housings, the appropriate differential depends on the degree of interference and the seat diameter. However, a moderate increase in temperature will usually suffice. An even and risk-free heating of CARB bearings can be achieved using an induction heater (→ **fig. 2**).

Mounting on a tapered seat

A CARB toroidal roller bearing with a tapered bore is always mounted on the shaft with an interference fit. To determine the degree of interference, any one of the following methods can be used:

- Measuring clearance reduction.
- Measuring lock nut tightening angle.
- Measuring axial drive-up.
- Measuring inner ring expansion.

Mounting dolly with abutment faces for both bearing rings in the same plane

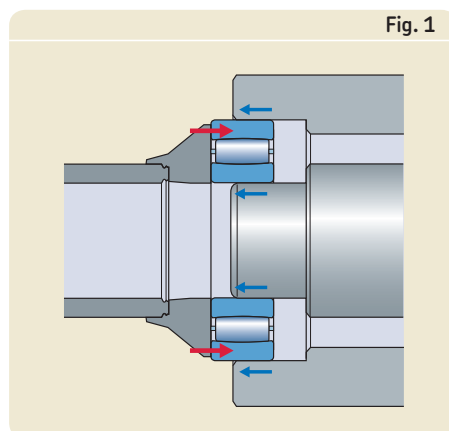

Fig. 1

SKF induction heater

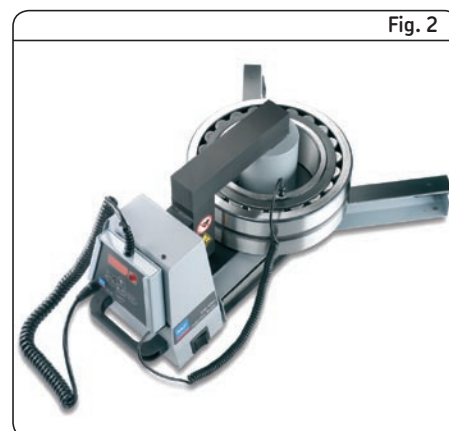

Fig. 2

For CARB toroidal roller bearings with bore diameters greater than or equal to 50 mm, SKF recommends the SKF drive-up method. This method is more accurate and takes less time than the procedure based on measuring clearance reduction.

Sound in CARB bearings

A rolling bearing generates a specific inherent sound during operation. Depending on the bearing type, the radial operating clearance can, to some extent, determine the sound level.

CARB bearings belong to a group of bearings where a large operating clearance can substantially influence the sound level. Therefore, SKF recommends selecting an operating clearance not larger than necessary to keep the sound at a low level.

Measuring clearance reduction

Prior to mounting, the internal radial clearance must be measured with a feeler gauge between the outer ring and an unloaded roller. Before measuring, the bearing should be rotated a few times to make sure that the rollers have assumed their correct position. For the first measurement a blade should be selected that is slightly thinner than the minimum clearance value. During the measurement, the blade should be moved back and forth (→ fig. 3) until it reaches the middle of the roller. The procedure should be repeated using slightly thicker blades each time until there is light resistance.

During mounting, the reduction in clearance should be measured between the outer

Move the blade back and forth between roller and outer ring

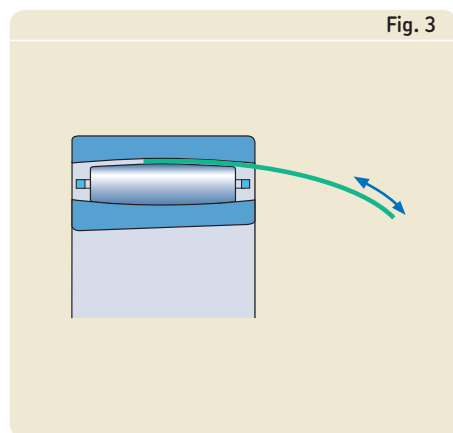

ring raceway and the lowest roller (→ fig. 4). Again the bearing should be rotated a few times between each measurement.

Recommended values for the clearance reduction and axial drive-up are provided in **table 2 on page 28**. They are valid for solid steel shafts and normal operating conditions ($C/P > 10$). Where loads are heavy ($C/P < 10$), speeds are high or there is a considerable temperature gradient across the bearing, greater clearance reductions or axial drive-up are required and thus bearings with greater initial radial internal clearance might be needed.

The values provided in **table 2 on page 28** for the clearance reduction apply mainly to bearings having initial clearances close to the lower limits for clearance provided in **table 2 on page 39**.

Measuring the lock nut tightening angle

Smaller bearings can be mounted easily using the tightening angle α that the nut is turned to drive the bearing up onto its tapered seat. Where applicable, the tightening angle α is listed in **table 1**. Before mounting, the thread and side face of the nut should be coated with a molybdenum disulphide paste or similar lubricant and the seat should be coated with a thin layer of light oil. Then push the bearing onto the tapered seat until the bore of the bearing or sleeve is in contact with the seat on the shaft around its whole circumference, i.e. the bearing inner ring cannot be rotated relatively to the shaft. By then tightening the nut through the recommended angle α the bearing will be pressed up on the tapered

Measuring clearance during the mounting procedure

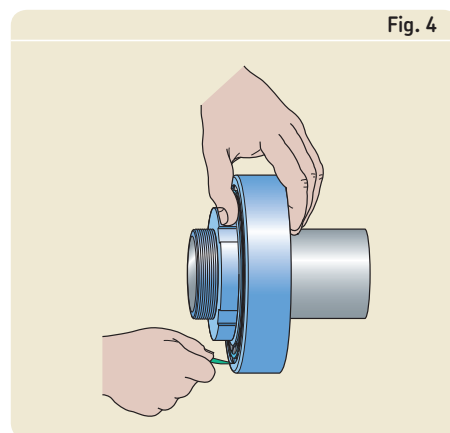

seat. As the bearing has a tendency to skew when being pressed into place it is advisable to reposition the hook spanner in a slot at 180° to that used for tightening and then gently tap the hook spanner. The bearing will straighten up on its seat. Finally, check the residual clearance of the bearing.

Table 1

Angular drive-up for CARB bearings

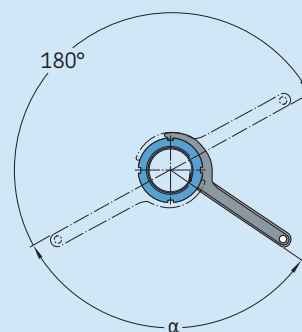

Bearing designation	Tightening angle α	Clearance reduction	Axial drive-up
–	degrees	mm	mm
C 2205 K	100	0,011	0,42
C 2206 K	105	0,013	0,45
C 2207 K	115	0,016	0,48
C 2208 K	125	0,018	0,52
C 2209 K	130	0,020	0,54
C 2210 K	140	0,023	0,58
C 2211 K	110	0,025	0,60
C 2212 K	115	0,027	0,65
C 2213 K	120	0,029	0,67
C 2214 K	125	0,032	0,69
C 2215 K	130	0,034	0,72
C 2216 K	140	0,036	0,77
C 2217 K	145	0,038	0,80
C 2218 K	150	0,041	0,84
C 2219 K	150	0,043	0,84
C 2220 K	155	0,045	0,87
C 2222 K	170	0,050	0,95
C 2314 K	130	0,032	0,72
C 2315 K	135	0,034	0,75
C 2316 K	140	0,036	0,78
C 2317 K	145	0,038	0,81
C 2318 K	155	0,041	0,86
C 2319 K	155	0,043	0,87
C 2320 K	160	0,045	0,9

Measuring the axial drive-up

The SKF drive-up method is based on measuring the axial displacement of the bearing inner ring on its tapered seat from a reliably determined starting position.

The SKF drive-up method (→ fig. 5) requires the use of an SKF HMV .. E hydraulic nut that can accommodate a dial gauge. A pressure gauge, appropriate to the mounting conditions, mounted on a suitably sized hand pump, enables accurate pressure measurement to determine the starting position. The tools required are shown in fig. 6.

Guideline values for

- the requisite oil pressure
- the axial displacement

for the individual bearings are provided in table 3, starting on page 30.

Table 2

Recommended values for reduction of radial internal clearance and axial drive-up

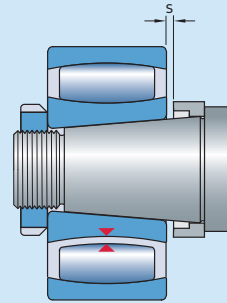

Bore diameter d		Reduction of radial internal clearance		Axial drive-up s ¹⁾				Check values for the smallest radial clearance ²⁾ after mounting bearings with initial clearance		
over	incl.	min	max	Taper 1:12		Taper 1:30		Normal	C3	C4
mm		mm		mm		mm		mm		
24	30	0,012	0,018	0,25	0,34	0,64	0,85	0,025	0,033	0,047
30	40	0,015	0,024	0,30	0,42	0,74	1,06	0,031	0,038	0,056
40	50	0,020	0,030	0,37	0,51	0,92	1,27	0,033	0,043	0,063
50	65	0,025	0,039	0,44	0,64	1,09	1,59	0,038	0,049	0,074
65	80	0,033	0,048	0,54	0,76	1,36	1,91	0,041	0,055	0,088
80	100	0,040	0,060	0,65	0,93	1,62	2,33	0,056	0,072	0,112
100	120	0,050	0,072	0,79	1,10	1,98	2,75	0,065	0,083	0,129
120	140	0,060	0,084	0,93	1,27	2,33	3,18	0,075	0,106	0,147
140	160	0,070	0,096	1,07	1,44	2,68	3,60	0,085	0,126	0,173
160	180	0,080	0,108	1,21	1,61	3,04	4,02	0,093	0,140	0,193
180	200	0,090	0,120	1,36	1,78	3,39	4,45	0,103	0,150	0,209
200	225	0,100	0,135	1,50	1,99	3,74	4,98	0,113	0,163	0,228
225	250	0,113	0,150	1,67	2,20	4,18	5,51	0,123	0,175	0,251
250	280	0,125	0,168	1,85	2,46	4,62	6,14	0,133	0,186	0,276
280	315	0,140	0,189	2,06	2,75	5,15	6,88	0,143	0,198	0,292
315	355	0,158	0,213	2,31	3,09	5,77	7,73	0,161	0,226	0,329
355	400	0,178	0,240	2,59	3,47	6,48	8,68	0,173	0,251	0,358
400	450	0,200	0,270	2,91	3,90	7,27	9,74	0,183	0,275	0,383
450	500	0,225	0,300	3,26	4,32	8,15	10,80	0,210	0,295	0,433
500	560	0,250	0,336	3,61	4,83	9,04	12,07	0,225	0,327	0,467
560	630	0,280	0,378	4,04	5,42	10,09	13,55	0,250	0,364	0,508
630	710	0,315	0,426	4,53	6,10	11,33	15,25	0,275	0,386	0,560
710	800	0,355	0,480	5,10	6,86	12,74	17,15	0,319	0,430	0,620
800	900	0,400	0,540	5,73	7,71	14,33	19,27	0,335	0,465	0,675
900	1 000	0,450	0,600	6,44	8,56	16,09	21,39	0,364	0,490	0,740
1 000	1 120	0,500	0,672	7,14	9,57	17,86	23,93	0,395	0,543	0,823
1 120	1 250	0,560	0,750	7,99	10,67	19,98	26,68	0,414	0,595	0,885

¹⁾ Valid only for solid steel shafts and general application. Not valid for the SKF drive-up method

²⁾ The residual clearance must be checked in cases where the initial radial internal clearance is in the lower half of the tolerance range and where large temperature differentials between the bearing rings can arise in operation. When measuring, make sure that the rings and the roller assembly are aligned and centred

Fig. 5

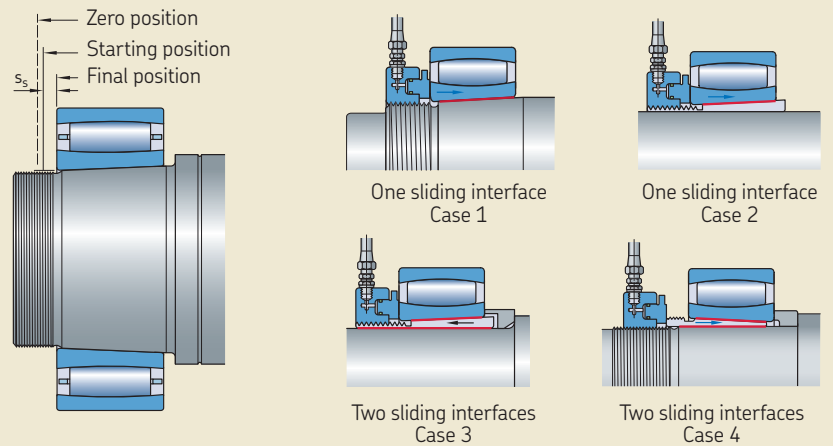

1. Check whether the bearing size and the HMV .. E hydraulic nut coincide. Otherwise the values for the requisite pressure provided in **table 3**, starting on **page 30**, must be adjusted (→ note on **page 33**).
2. Check the number of sliding interfaces (→ above).
3. Lightly coat the sliding surfaces with a thin oil, e.g. SKF LHM 300, and place the bearing on the tapered journal or sleeve. Screw the hydraulic nut onto the thread of the journal or sleeve so that it abuts the bearing. Then connect the appropriate oil pump (→ **fig. 6**).
4. Bring the bearing to its starting position. Pump oil into the hydraulic nut until the requisite pressure quoted in **table 3**, starting on **page 30**, is reached.
5. Set the dial gauge to "zero" (→ **fig. 6**) and pump more oil into the hydraulic nut until the bearing has been driven up the distance prescribed in **table 3**, starting on **page 30**, and is in its final position.
6. When mounting is complete, release the return valve of the oil pump, so that oil under high pressure in the nut can flow back out of the nut.
7. To remove all the oil from the nut, bring the piston of the hydraulic nut to its original position. This is most easily done by screwing the nut further up the threaded portion of the journal or sleeve.
8. Remove the nut from the shaft by unscrewing and replace it with a lock nut.

The SKF drive-up method

Fig. 6

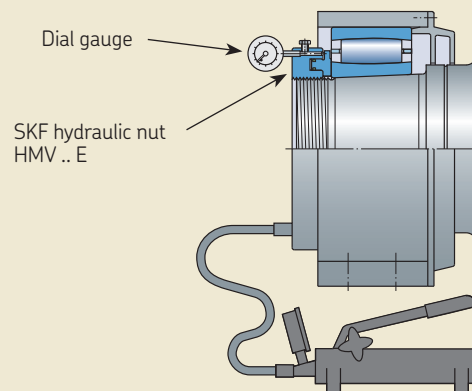

SKF pump 729124 SRB (for nuts up to and including HMV 54 E)
 SKF pump TML 50 SRB (for nuts up to and including HMV 170 E)

Suitable tools for the SKF drive-up method

Table 3

Basic bearing designation	Starting position		Final position		Radial clearance reduction from zero position Δ_r	Hydraulic nut Designation	Piston area
	Requisite oil pressure for one sliding interface ¹⁾	two sliding interfaces ¹⁾	Axial displacement from starting position one sliding interface ¹⁾ s_s	two sliding interfaces ¹⁾ s_s			
–	MPa		mm		mm	–	mm ²
C 22 series							
C 2210 K	0,67	1,15	0,34	0,41	0,023	HMV 10 E	2 900
C 2211 K	0,57	0,98	0,35	0,42	0,025	HMV 11 E	3 150
C 2212 K	1,09	1,86	0,39	0,47	0,027	HMV 12 E	3 300
C 2213 K	0,82	1,40	0,40	0,47	0,029	HMV 13 E	3 600
C 2214 K	0,76	1,29	0,43	0,50	0,032	HMV 14 E	3 800
C 2215 K	0,70	1,20	0,45	0,52	0,034	HMV 15 E	4 000
C 2216 K	1,03	1,76	0,48	0,55	0,036	HMV 16 E	4 200
C 2217 K	1,12	1,91	0,50	0,57	0,038	HMV 17 E	4 400
C 2218 K	1,36	2,32	0,55	0,62	0,041	HMV 18 E	4 700
C 2219 K	1,02	1,74	0,54	0,62	0,043	HMV 19 E	4 900
C 2220 K	1,12	1,90	0,57	0,64	0,045	HMV 20 E	5 100
C 2222 K	1,49	2,54	0,63	0,71	0,050	HMV 22 E	5 600
C 2224 K	1,58	2,69	0,67	0,74	0,054	HMV 24 E	6 000
C 2226 K	1,44	2,46	0,71	0,79	0,059	HMV 26 E	6 400
C 2228 K	2,36	4,03	0,79	0,86	0,063	HMV 28 E	6 800
C 2230 K	1,79	3,05	0,82	0,89	0,068	HMV 30 E	7 500
C 2234 K	2,58	4,40	0,94	1,01	0,076	HMV 34 E	9 400
C 2238 K	1,77	3,01	1,01	1,08	0,086	HMV 38 E	11 500
C 2244 K	1,95	3,34	1,15	1,22	0,100	HMV 44 E	14 400
C 23 series							
C 2314 K	2,01	3,43	0,46	0,53	0,032	HMV 14 E	3 800
C 2315 K	2,25	3,84	0,48	0,55	0,034	HMV 15 E	4 000
C 2316 K	2,11	3,61	0,49	0,56	0,036	HMV 16 E	4 200
C 2317 K	2,40	4,10	0,52	0,59	0,038	HMV 17 E	4 400
C 2318 K	2,88	4,91	0,57	0,64	0,041	HMV 18 E	4 700
C 2319 K	2,22	3,79	0,57	0,64	0,043	HMV 19 E	4 900
C 2320 K	2,56	4,36	0,59	0,66	0,045	HMV 20 E	5 100
C 2326 K	2,71	4,62	0,73	0,81	0,059	HMV 26 E	6 400
C 30 series							
C 3022 K	0,97	1,66	0,62	0,69	0,050	HMV 22 E	5 600
C 3024 K	0,92	1,58	0,65	0,72	0,054	HMV 24 E	6 000
C 3026 K	1,23	2,10	0,72	0,79	0,056	HMV 26 E	6 400
C 3028 K	1,25	2,13	0,76	0,83	0,063	HMV 28 E	6 800
C 3030 K	1,02	1,73	0,80	0,87	0,068	HMV 30 E	7 500
C 3032 K	1,33	2,26	0,86	0,93	0,072	HMV 32 E	8 600
C 3034 K	1,52	2,60	0,90	0,98	0,076	HMV 34 E	9 400
C 3036 K	1,43	2,44	0,95	1,02	0,081	HMV 36 E	10 300
C 3038 K	1,60	2,73	1,02	1,09	0,086	HMV 38 E	11 500
C 3040 K	1,62	2,76	1,06	1,13	0,090	HMV 40 E	12 500
C 3044 K	1,58	2,69	1,15	1,22	0,099	HMV 44 E	14 400
C 3048 K	1,34	2,29	1,23	1,30	0,108	HMV 48 E	16 500
C 3052 K	1,77	3,02	1,35	1,43	0,117	HMV 52 E	18 800
C 3056 K	1,69	2,89	1,52	1,45	0,126	HMV 56 E	21 100
C 3060 K	1,85	3,16	1,55	1,62	0,135	HMV 60 E	23 600
C 3064 K	1,80	3,08	1,65	1,72	0,144	HMV 64 E	26 300
C 3068 K	2,04	3,48	1,76	1,83	0,153	HMV 68 E	28 400
C 3072 K	1,65	2,82	1,82	1,89	0,162	HMV 72 E	31 300

¹⁾ The quoted values are for hydraulic nuts, the thread diameter of which corresponds to the bore diameter of the bearing to be mounted and for applications with sliding surfaces coated with a thin layer of light oil

Continuation Table 3

Basic bearing designation	Starting position		Final position		Radial clearance reduction from zero position Δ_r	Hydraulic nut Designation	Piston area
	Requisite oil pressure for one sliding interface ¹⁾	two sliding interfaces ¹⁾	Axial displacement from one sliding interface ¹⁾ s_s	two sliding interfaces ¹⁾ s_s			
–	MPa		mm		mm	–	mm ²
C 30 series							
C 3076 K	1,36	2,32	1,88	1,95	0,171	HMV 76 E	33 500
C 3080 K	1,54	2,63	1,99	2,06	0,180	HMV 80 E	36 700
C 3084 K	1,34	2,29	2,07	2,14	0,189	HMV 84 E	40 000
C 3088 K	1,22	2,08	2,14	2,21	0,198	HMV 88 E	42 500
C 3092 K	2,00	3,42	2,33	2,41	0,207	HMV 92 E	45 100
C 3096 K	1,75	2,99	2,40	2,47	0,216	HMV 96 E	48 600
C 30/500 K	1,56	2,66	2,47	2,54	0,225	HMV 100 E	51 500
C 30/530 K	1,54	2,63	2,60	2,68	0,239	HMV 106 E	56 200
C 30/560 K	2,26	3,85	2,84	2,91	0,252	HMV 112 E	61 200
C 30/600 K	1,92	3,28	2,98	3,06	0,270	HMV 120 E	67 300
C 30/630 K	1,68	2,87	3,09	3,16	0,284	HMV 126 E	72 900
C 30/670 K	2,12	3,61	3,34	3,41	0,302	HMV 134 E	79 500
C 30/710 K	1,73	2,96	3,47	3,54	0,320	HMV 142 E	87 700
C 30/750 K	1,89	3,22	3,68	3,75	0,338	HMV 150 E	95 200
C 30/800 K	1,88	3,22	3,91	3,98	0,360	HMV 160 E	103 900
C 30/850 K	1,90	3,24	4,15	4,22	0,383	HMV 170 E	114 600
C 30/900 K	1,60	2,73	4,32	4,39	0,405	HMV 180 E	124 100
C 30/950 K	1,94	3,30	4,62	4,69	0,428	HMV 190 E	135 700
C 30/1000 K	1,93	3,30	4,85	4,92	0,450	HMV 200 E	145 800
C 31 series							
C 3120 K	1,27	2,16	0,57	0,64	0,045	HMV 20 E	5 100
C 3130 K	2,41	4,12	0,84	0,91	0,068	HMV 30 E	7 500
C 3132 K	2,07	3,54	0,87	0,94	0,072	HMV 32 E	8 600
C 3134 K	1,84	3,13	0,90	0,97	0,076	HMV 34 E	9 400
C 3136 K	1,71	2,92	0,94	1,01	0,081	HMV 36 E	10 300
C 3138 K	2,27	3,87	1,02	1,10	0,086	HMV 38 E	11 500
C 3140 K	2,71	4,63	1,08	1,16	0,090	HMV 40 E	12 500
C 3144 K	2,76	4,71	1,18	1,26	0,099	HMV 44 E	14 400
C 3148 K	2,01	3,44	1,24	1,31	0,108	HMV 48 E	16 500
C 3152 K	2,76	4,70	1,37	1,44	0,117	HMV 52 E	18 800
C 3156 K	2,63	4,49	1,47	1,54	0,126	HMV 56 E	21 100
C 3160 K	2,81	4,79	1,57	1,64	0,135	HMV 60 E	23 600
C 3164 K	2,09	3,56	1,61	1,68	0,144	HMV 64 E	26 300
C 3168 K	2,84	4,85	1,75	1,82	0,153	HMV 68 E	28 400
C 3172 K	2,46	4,20	1,83	1,90	0,162	HMV 72 E	31 300
C 3176 K	2,57	4,39	1,93	2,01	0,171	HMV 76 E	33 500
C 3180 K	3,32	5,66	2,10	2,17	0,180	HMV 80 E	36 700
C 3188 K	2,38	4,06	2,20	2,27	0,198	HMV 88 E	42 500
C 3184 K	3,29	5,62	2,17	2,25	0,189	HMV 84 E	40 000
C 3192 K	3,57	6,09	2,39	2,46	0,207	HMV 92 E	45 100
C 3196 K	3,51	6,00	2,48	2,56	0,216	HMV 96 E	48 600
C 31/500 K	3,54	6,04	2,57	2,64	0,225	HMV 100 E	51 500
C 31/530 K	3,40	5,81	2,71	2,79	0,239	HMV 106 E	56 200
C 31/560 K	3,11	5,30	2,83	2,90	0,252	HMV 112 E	61 200
C 31/600 K	3,15	5,38	3,01	3,09	0,270	HMV 120 E	67 300
C 31/630 K	3,36	5,74	3,18	3,26	0,284	HMV 126 E	72 900
C 31/670 K	3,48	5,95	3,38	3,45	0,302	HMV 134 E	79 500

¹⁾ The quoted values are for hydraulic nuts, the thread diameter of which corresponds to the bore diameter of the bearing to be mounted and for applications with sliding surfaces coated with a thin layer of light oil

Continuation Table 3

Basic bearing designation	Starting position		Final position		Radial clearance reduction from zero position Δ_r	Hydraulic nut Designation	Piston area
	Requisite oil pressure for one sliding interface ¹⁾	two sliding interfaces ¹⁾	Axial displacement from starting position one sliding interface ¹⁾ s_s	two sliding interfaces ¹⁾ s_s			
–	MPa		mm		mm	–	mm ²
C 31 series							
C 31/710 K	3,58	6,10	3,59	3,67	0,320	HMV 142 E	87 700
C 31/750 K	3,52	6,00	3,77	3,84	0,338	HMV 150 E	95 200
C 31/800 K	3,55	6,06	4,01	4,09	0,360	HMV 160 E	103 900
C 31/850 K	4,02	6,86	4,32	4,39	0,383	HMV 170 E	114 600
C 31/1000 K	3,69	6,30	4,97	5,04	0,450	HMV 200 E	145 800
C 32 series							
C 3224 K	2,46	4,20	0,69	0,76	0,054	HMV 24 E	6 000
C 3232 K	2,68	4,58	0,87	0,94	0,072	HMV 32 E	8 600
C 3234 K	3,87	6,60	0,96	1,03	0,076	HMV 34 E	9 400
C 3236 K	3,69	6,30	1,01	1,09	0,081	HMV 36 E	10 300
C 39 series							
C 3972 K	0,63	1,08	1,74	1,81	0,162	HMV 72 E	31 300
C 3976 K	1,06	1,81	1,88	1,95	0,171	HMV 76 E	33 500
C 3980K	0,74	1,27	1,93	2,00	0,180	HMV 80 E	36 700
C 3984 K	0,73	1,25	2,03	2,10	0,189	HMV 84 E	40 000
C 3988 K	1,05	1,79	2,16	2,23	0,198	HMV 88 E	42 500
C 3992 K	0,82	1,41	2,22	2,29	0,207	HMV 92 E	45 100
C 3996 K	1,18	2,01	2,37	2,44	0,216	HMV 96 E	48 600
C 39/500 K	0,95	1,63	2,43	2,50	0,225	HMV 100 E	51 500
C 39/530 K	0,73	1,25	2,52	2,59	0,239	HMV 106 E	56 200
C 39/560 K	0,96	1,64	2,70	2,78	0,252	HMV 112 E	61 200
C 39/600 K	1,00	1,71	2,89	2,96	0,270	HMV 120 E	67 300
C 39/630 K	1,05	1,80	3,03	3,11	0,284	HMV 126 E	72 900
C 39/670 K	1,44	2,46	3,31	3,38	0,302	HMV 134 E	79 500
C 39/710 K	0,81	1,39	3,35	3,42	0,320	HMV 142 E	87 700
C 39/750 K	1,06	1,80	3,59	3,66	0,338	HMV 150 E	95 200
C 39/800 K	1,13	1,93	3,83	3,90	0,360	HMV 160 E	103 900
C 39/850 K	1,09	1,85	4,06	4,14	0,383	HMV 170 E	114 600
C 39/900 K	1,00	1,70	4,26	4,34	0,405	HMV 180 E	124 100
C 39/950 K	1,04	1,77	4,50	4,57	0,428	HMV 190 E	135 700

¹⁾ The quoted values are for hydraulic nuts, the thread diameter of which corresponds to the bore diameter of the bearing to be mounted and for applications with sliding surfaces coated with a thin layer of light oil

Note

The values provided in **table 3** for the requisite oil pressure and the axial displacement s_s apply to bearings mounted on solid steel shafts for the first time. For the case 4 shown in **fig. 5** on **page 29** “Two sliding interfaces” (bearing on a withdrawal sleeve), the guideline values provided in **table 3** do not apply as a smaller hydraulic nut is used than that shown for the bearing in **table 3**.

The requisite oil pressure can be calculated from

$$P_{\text{req}} = \frac{A_{\text{ref}}}{A_{\text{req}}} P_{\text{ref}}$$

where

P_{req} = requisite oil pressure for hydraulic nut used, MPa

P_{ref} = oil pressure specified for the standard hydraulic nut, MPa
(→ **table 3**)

A_{ref} = piston area of the specified standard hydraulic nut, mm²
(→ **table 3**)

A_{req} = piston area of the hydraulic nut used, mm² (→ **table 3**)

Measuring inner ring expansion

Measuring inner ring expansion enables large size CARB bearings with a tapered bore to be mounted easily, quickly and accurately without measuring the radial internal clearance before and after mounting. The SensorMount method uses a sensor, integrated into the inner ring of a CARB toroidal roller bearing and a dedicated hand-held indicator (→ **fig. 7**).

The bearing is driven up the tapered seat using common SKF mounting tools. Information from the sensor is processed by the indicator. Inner ring expansion is displayed as the relationship between the clearance reduction (mm) and the bearing bore diameter (m).

Aspects like bearing size, smoothness, shaft material or design – solid or hollow do not need to be considered.

For detailed information about SensorMount contact SKF.

Additional mounting information

Additional information on mounting CARB toroidal roller bearings can be found

- in the handbook “SKF Drive-up Method” on CD-ROM
- in the “SKF Interactive Engineering Catalogue” online at www.skf.com
- online at www.skf.com/mount.

SensorMount method

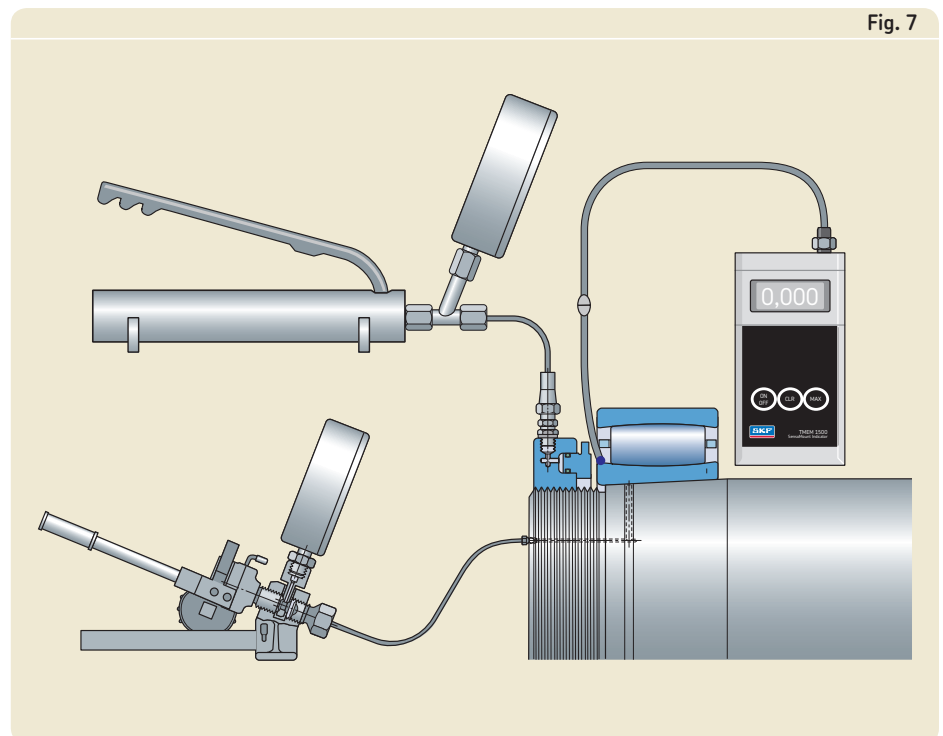

Fig. 7

Dismounting

If CARB toroidal roller bearings are to be re-used after dismounting, the force used for dismounting should never pass through the rollers. The ring with the looser fit should be withdrawn from its seat first. There are three methods available to dismount the bearing ring that has been mounted with an interference fit: mechanical, hydraulic or the oil injection method.

Detailed information on the dismounting of bearings is contained in the publication “SKF Bearing Maintenance Handbook”.

Dismounting from a cylindrical seat

CARB toroidal roller bearings, with a bore diameter up to approximately 120 mm and that have been mounted with an interference fit on the shaft, can be removed using a conventional puller. The puller should be applied to the side face of the ring to be dismounted (→ **fig. 1**). By turning the puller spindle the bearing is easily removed from the cylindrical seat.

For larger bearings, the withdrawal forces are considerable. In these cases, the use of pullers with hydraulic assistance (→ **fig. 2**) or the SKF oil injection method should be used.

CARB toroidal roller bearings that have an interference fit for both rings should be pressed out of the housing together with the shaft. On the other hand it is also possible to withdraw the bearing, together with its housing, from the shaft, particularly if the oil injection method is applied (→ **fig. 3**).

Small CARB toroidal roller bearings mounted with an interference fit in a housing bore without shoulders can be removed using a dolly applied to the outer ring. Larger bearings require more force to remove them and a press is required.

The puller is applied to the side face of the inner ring

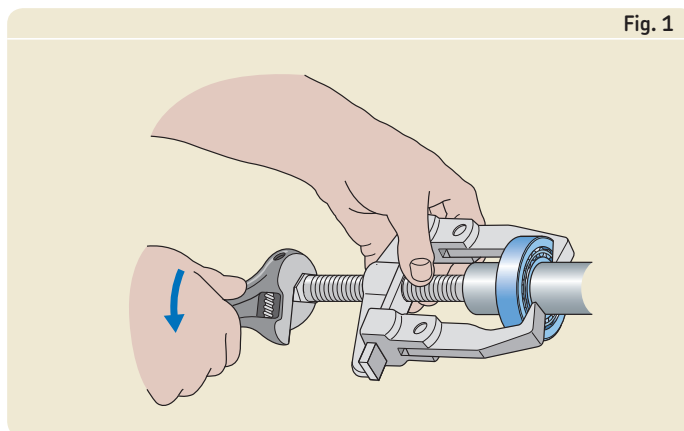

SKF puller with hydraulic assistance

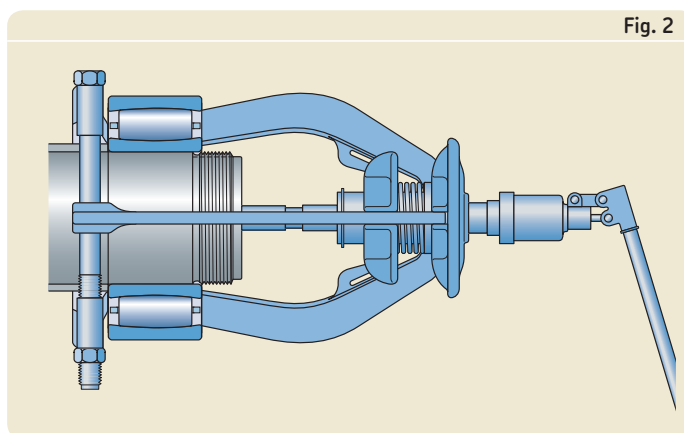

CARB toroidal roller bearing on a cylindrical seat being removed using the SKF oil injection method

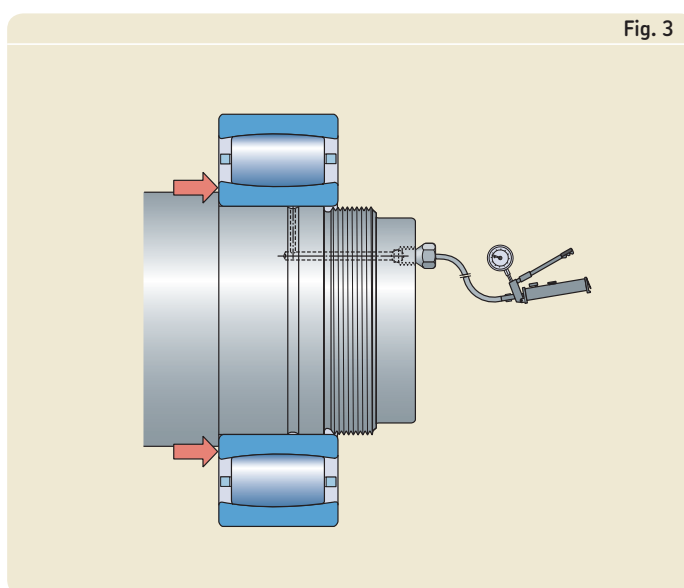

Various larger CARB toroidal roller bearings that have a loose or a transition fit in the housing can be removed using a tool with hooks that pass between the rollers and grip the outer ring from behind (→ **fig. 4**), so that the withdrawal forces are applied directly to the outer ring and the rollers do not become jammed between the rings.

Dismounting from a tapered seat

When dismounting, bearings with a tapered bore come free from their seat very suddenly, it is therefore necessary to provide a stop of some sort to limit their axial movement. An end plate screwed to a shaft end or a lock nut (→ **fig. 5**) serve this purpose. The lock nut should be unscrewed a few turns.

Small CARB toroidal roller bearings can be removed with the aid of a dolly or a drift of special design (→ **fig. 6**). A few blows directed at the dolly are sufficient to drive the inner ring from its tapered seat.

Medium-sized CARB toroidal roller bearings can be withdrawn using a mechanical puller or a puller with a hydraulic assistance. To avoid damaging the bearing, the puller should be applied centrally.

The removal of large bearings is greatly facilitated if the oil injection method is used.

Schematic sketch of a tool to remove CARB bearings from a non-split housing

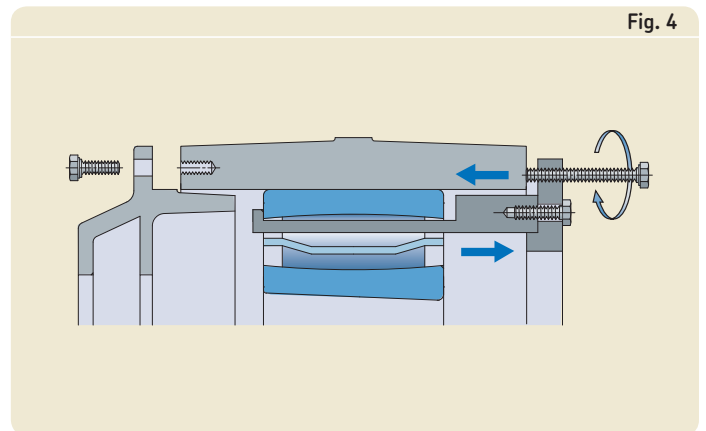

Fig. 4

The lock nut is left on the shaft thread to provide a stop

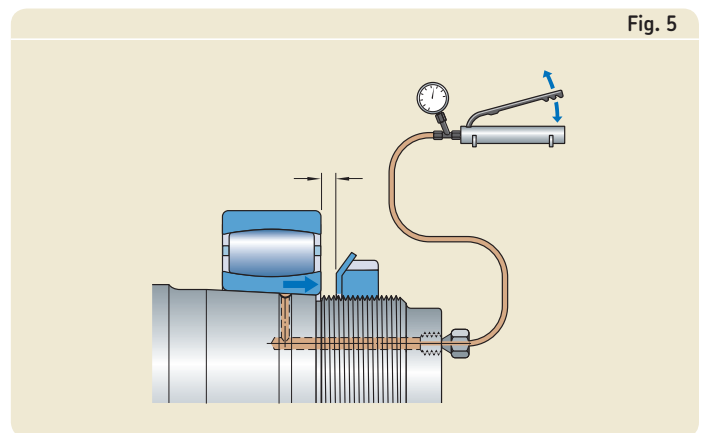

Fig. 5

Removal of a small CARB toroidal roller bearing using a drift of special design

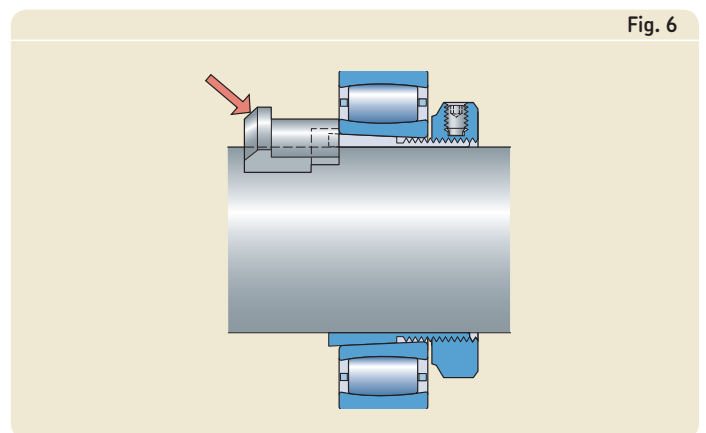

Fig. 6

The SKF concept for cost savings

A daily occurrence

Whatever the industry – unplanned stoppages are still not a thing of the past. They are not only annoying, but can be costly too. And with the heightened demands for prompt and just-in-time deliveries they may be even more expensive.

The SKF answer

The bearings in a machine can be likened to the heart of a living being. When the bearings malfunction, the machine has a problem. And just as a doctor will listen to the heart of a patient, it is possible to listen to the bearings to determine if they are in danger of premature failure.

If the importance of the bearings is overlooked, it will inevitably lead to high costs, unnecessary stoppages and, in the worst case, damage to other machine components.

Instead, SKF recommends to make use of one of its services: an Integrated Maintenance Solutions (IMS) contract, which consists of linking customers with SKF resources.

This involves a multi-stage programme that includes the following points

- common problem definition and target setting
- optimization of stocked spares
- reduction of purchasing costs
- choosing the right bearings
- caring for the bearings
- monitoring the machine condition
- having the appropriate tools and lubricants on hand
- customer-specific training
- a repair service.

Obviously it is possible to accept the whole programme or to select only parts of it. Whatever the choice, it will be a win-win situation. More information can be obtained from the nearest SKF office or authorized distributor.

Monitoring temperature



Registering vibration levels

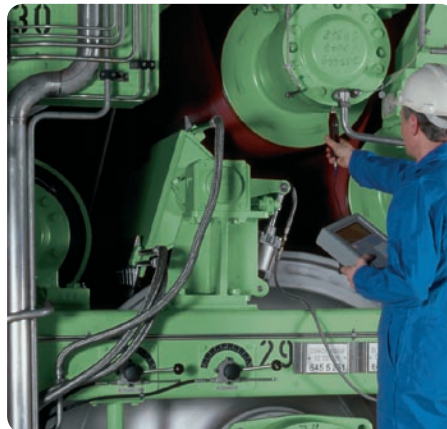

SKF experts bring their experience to lubricant analysis



Bearing data – general

Designs

CARB toroidal roller bearings are available

- with a caged roller assembly (→ **fig. 1**)
- in a full complement version (→ **fig. 2**).

Both versions are produced with a cylindrical bore, but most caged bearings are also produced with a tapered bore. Depending on the bearing series, the taper is either 1:12 or 1:30.

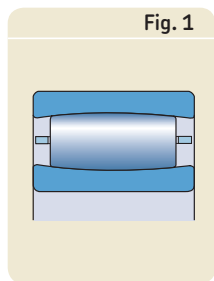

Fig. 1

Caged CARB toroidal roller bearing

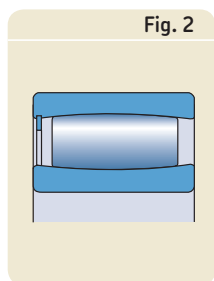

Fig. 2

Full complement CARB toroidal roller bearing

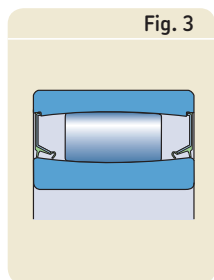

Fig. 3

Sealed CARB toroidal roller bearing

Sealed bearings

Today, the range of sealed bearings (→ **fig. 3**) consists of small and medium size full complement bearings for low speeds. These bearings, with a seal on both sides, are filled with a high temperature long life grease and do not require relubrication.

The double lip seal, suitable for high temperature operation, is sheet steel reinforced and made of hydrogenated acrylonitrile butadiene rubber (HNBR). It seals against the inner ring raceway. The outside diameter of the seal is retained in an outer ring recess and provides proper sealing, even in applications with outer ring rotation. The seals can withstand operating temperatures ranging from -40 to $+150$ °C (-40 to $+300$ °F).

The sealed bearings are filled with a premium quality, synthetic ester oil based grease using polyurea as a thickener. This grease has good corrosion inhibiting properties and has a temperature range of -25 to $+180$ °C (-15 to $+355$ °F)¹⁾. The base oil viscosity is 440 mm²/s at 40 °C and 38 mm²/s at 100 °C. The grease fill is 70 to 100 % of the free space in the bearing.

Sealed bearings with other lubricating greases or degrees of grease fill can be supplied on request.

Bearings for vibratory applications

For non-locating bearings in vibratory applications SKF manufactures CARB toroidal roller bearings with a surface hardened pressed steel cage in the C 23/C4VG114 series with a cylindrical bore. These bearings have the same dimensions and product data as bearings in the C 23 series. They enable a press fit on the shaft to avoid fretting corrosion that otherwise would be caused by a loose fit on the shaft. Using CARB bearings in vibratory applications in the non-locating position results in a self-aligning bearing system with better performance and reliability.

For additional information on CARB bearings in the C 23/C4VG114 series, consult the SKF application engineering service.

Dimensions

The boundary dimensions of CARB toroidal roller bearings are in accordance with ISO 15:1998. The dimensions of the adapter and withdrawal sleeves correspond to ISO 2982-1:1995.

Tolerances

CARB toroidal roller bearings are manufactured as standard to Normal tolerances. Bearings up to and including 300 mm bore diameter are produced to higher precision than the ISO Normal tolerances. For example

- the width tolerance is considerably tighter than the ISO Normal tolerance
- the running accuracy is to tolerance class P5 as standard.

For larger bearing arrangements where running accuracy is a key operational parameter, CARB bearings with P5 running accuracy are also available. These bearings are identified by the suffix C08. Their availability should be checked.

The values of the tolerances are in accordance with ISO 492:2002.

¹⁾ The safe operating temperature range for this grease according to the "SKF traffic light concept" is $+60$ to $+140$ °C

Table 1

Radial internal clearance of CARB toroidal roller bearings with a cylindrical bore											
Bore diameter d		Radial internal clearance									
		C2		Normal		C3		C4		C5	
over	incl.	min	max	min	max	min	max	min	max	min	max
mm		µm									
18	24	15	27	27	39	39	51	51	65	65	81
24	30	18	32	32	46	46	60	60	76	76	94
30	40	21	39	39	55	55	73	73	93	93	117
40	50	25	45	45	65	65	85	85	109	109	137
50	65	33	54	54	79	79	104	104	139	139	174
65	80	40	66	66	96	96	124	124	164	164	208
80	100	52	82	82	120	120	158	158	206	206	258
100	120	64	100	100	144	144	186	186	244	244	306
120	140	76	119	119	166	166	215	215	280	280	349
140	160	87	138	138	195	195	252	252	321	321	398
160	180	97	152	152	217	217	280	280	361	361	448
180	200	108	171	171	238	238	307	307	394	394	495
200	225	118	187	187	262	262	337	337	434	434	545
225	250	128	202	202	282	282	368	368	478	478	602
250	280	137	221	221	307	307	407	407	519	519	655
280	315	152	236	236	330	330	434	434	570	570	714
315	355	164	259	259	360	360	483	483	620	620	789
355	400	175	280	280	395	395	528	528	675	675	850
400	450	191	307	307	435	435	577	577	745	745	929
450	500	205	335	335	475	475	633	633	811	811	1 015
500	560	220	360	360	518	518	688	688	890	890	1 110
560	630	245	395	395	567	567	751	751	975	975	1 215
630	710	267	435	435	617	617	831	831	1 075	1 075	1 335
710	800	300	494	494	680	680	920	920	1 200	1 200	1 480
800	900	329	535	535	755	755	1 015	1 015	1 325	1 325	1 655
900	1 000	370	594	594	830	830	1 120	1 120	1 460	1 460	1 830
1 000	1 120	410	660	660	930	930	1 260	1 260	1 640	1 640	2 040
1 120	1 250	450	720	720	1 020	1 020	1 380	1 380	1 800	1 800	2 240

Internal clearance

CARB toroidal roller bearings are produced as standard with Normal radial internal clearance and most are also available with a larger C3 clearance. Many bearings can also be supplied with a smaller C2 clearance or with a much greater C4 or C5 clearance.

The radial internal clearance limits are listed for bearings with

- cylindrical bore in **table 1**
- tapered bore in **table 2**.

The limits are valid for bearings before mounting under zero measuring load, and with no axial displacement of one ring relative to the other.

Axial displacement of one ring relative to the other will gradually reduce the radial internal clearance in a CARB bearing. The amount of axial displacement encountered in applications where there is no external heat source on the shaft or foundation, will have little effect on the radial internal clearance.

CARB bearings are often used together with spherical roller bearings. The radial internal clearance of the CARB bearing is slightly larger than that of the corresponding spherical roller bearing having the same clearance class. An axial displacement of the inner ring relative to the outer ring of 6 to 8 % of the bearing width will reduce the operational clearance to approximately the same value as a spherical roller bearing of the same size.

Table 2

Radial internal clearance of CARB toroidal roller bearings with a tapered bore

Bore diameter d		Radial internal clearance									
		C2		Normal		C3		C4		C5	
over	incl.	min	max	min	max	min	max	min	max	min	max
mm		µm									
18	24	19	31	31	43	43	55	55	69	69	85
24	30	23	37	37	51	51	65	65	81	81	99
30	40	28	46	46	62	62	80	80	100	100	124
40	50	33	53	53	73	73	93	93	117	117	145
50	65	42	63	63	88	88	113	113	148	148	183
65	80	52	78	78	108	108	136	136	176	176	220
80	100	64	96	96	132	132	172	172	218	218	272
100	120	75	115	115	155	155	201	201	255	255	321
120	140	90	135	135	180	180	231	231	294	294	365
140	160	104	155	155	212	212	269	269	338	338	415
160	180	118	173	173	238	238	301	301	382	382	469
180	200	130	193	193	260	260	329	329	416	416	517
200	225	144	213	213	288	288	363	363	460	460	571
225	250	161	235	235	315	315	401	401	511	511	635
250	280	174	258	258	344	344	444	444	556	556	692
280	315	199	283	283	377	377	481	481	617	617	761
315	355	223	318	318	419	419	542	542	679	679	848
355	400	251	350	350	471	471	598	598	751	751	920
400	450	281	383	383	525	525	653	653	835	835	1 005
450	500	305	435	435	575	575	733	733	911	911	1 115
500	560	335	475	475	633	633	803	803	1 005	1 005	1 225
560	630	380	530	530	702	702	886	886	1 110	1 110	1 350
630	710	422	590	590	772	772	986	986	1 230	1 230	1 490
710	800	480	674	674	860	860	1 100	1 100	1 380	1 380	1 660
800	900	529	735	735	955	955	1 215	1 215	1 525	1 525	1 855
900	1 000	580	814	814	1 040	1 040	1 340	1 340	1 670	1 670	2 050
1 000	1 120	645	895	895	1 165	1 165	1 495	1 495	1 875	1 875	2 275
1 120	1 250	705	975	975	1 275	1 275	1 635	1 635	2 055	2 055	2 495

Misalignment

During operation, angular misalignment of up to $0,5^\circ$ between the inner and outer rings (\rightarrow fig. 4) can usually be accommodated by a CARB toroidal roller bearing without any negative consequences for the bearing.

However, misalignment values greater than $0,5^\circ$ will increase friction and influence bearing service life. For misalignment greater than $0,5^\circ$ consult the SKF application engineering service. The ability to accommodate misalignment when the bearing is stationary is also limited. For CARB bearings with a machined brass cage centred on the inner ring, designation suffix MB, misalignment should never exceed $0,5^\circ$.

Misalignment displaces the rollers axially, causing them to approach the side faces of the bearing rings. Therefore, possible axial displacement should be reduced (\rightarrow "Axial displacement", starting on page 40).

Misaligned and displaced bearing rings

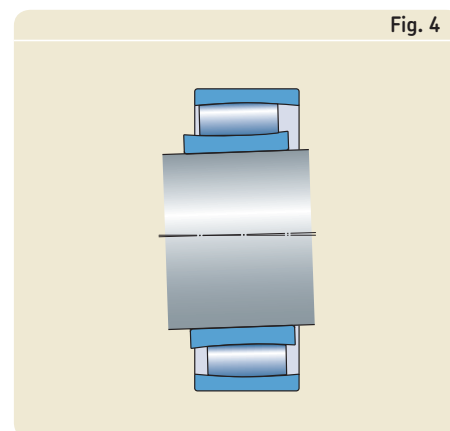

Axial displacement

CARB toroidal roller bearings can accommodate axial displacement of the shaft relative to the housing within the bearing. The axial displacement can result from thermal expansion or deviations from determined bearing positions.

Misalignment as well as axial displacement influences the axial position of the rollers in a CARB bearing. Axial displacement also reduces the radial clearance. SKF recommends checking that the axial displacement is within acceptable limits, i.e. the residual clearance is great enough, and that the rollers do not protrude outside the side face of a ring (→ **fig. 5a**) or contact any locking ring (→ **fig. 5b**) or seal. To accommodate the displacement of the roller and cage assembly, provide free space on both sides of the bearing as described in the section “Free space on the sides of the bearing” on **page 18**.

The axial displacement from the normal position of one bearing ring in relation to the other is limited by

- the displacement of the roller set
- the reduction of radial clearance.

The maximum possible axial displacement is obtained from the smaller of these two limitations.

Axial displacement limits s_1 and s_2

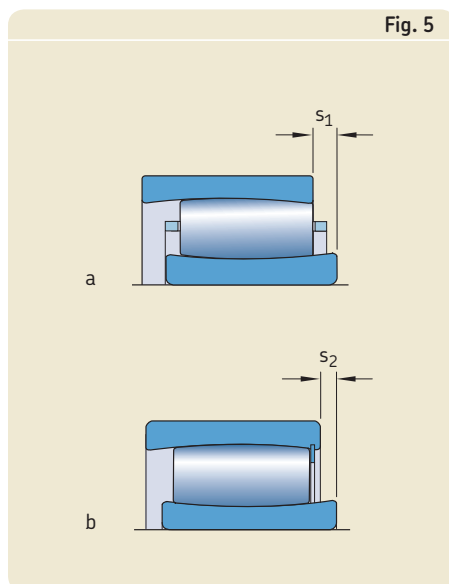

Fig. 5

Limitation caused by the displacement of the roller set

The guideline values s_1 and s_2 for axial displacement (→ **fig. 5**) listed in the product tables are valid provided

- there is a sufficiently large operational radial clearance in the bearing before shaft elongation
- the rings are not misaligned.

The reduction in the possible axial displacement caused by misalignment can be estimated using

$$s_{\text{mis}} = k_1 B \alpha$$

where

s_{mis} = reduction in axial displacement caused by misalignment, mm

k_1 = misalignment factor (→ product tables)

B = bearing width, mm (→ product tables)

α = misalignment, degrees

Assuming a sufficiently large operational clearance, the maximum possible axial displacement is obtained from

$$s_{\text{lim}} = s_1 - s_{\text{mis}}$$

or

$$s_{\text{lim}} = s_2 - s_{\text{mis}}$$

where

s_{lim} = possible axial displacement relative to the movement of the roller set caused by misalignment, mm

s_1 = guideline value for the axial displacement capability in bearings with a cage, sealed bearings or full complement bearings when displacing away from the snap ring, mm (→ product tables)

s_2 = guideline value for the axial displacement capability in sealed or full complement bearings when displacing towards the seal or snap ring respectively, mm (→ product tables)

s_{mis} = reduction in axial displacement caused by misalignment, mm

Limitation caused by the reduction of radial clearance

The reduction of radial clearance as a result of axial displacement from a centred position can be calculated using

$$C_{\text{red}} = \frac{k_2 s_{\text{cle}}^2}{B}$$

In cases where the reduction in clearance is greater than the radial clearance before shaft elongation, the bearing will be preloaded. If instead a certain radial clearance reduction is known, the corresponding axial displacement from a centred position can be calculated using

$$s_{\text{cle}} = \sqrt{\frac{B C_{\text{red}}}{k_2}}$$

where

s_{cle} = axial displacement from a centred position, corresponding to a certain radial clearance reduction, mm

C_{red} = reduction of radial clearance as a result of an axial displacement from a centred position, mm

k_2 = operating clearance factor (→ product tables)

B = bearing width, mm

The axial displacement capability can also be obtained using **diagram 1**, which is valid for all CARB bearings. The axial displacement and radial clearance are shown as functions of the bearing width.

From **diagram 1** it can be seen (dotted line) that for a bearing C 3052 K/HA3C4, with an operational clearance of 0,15 mm, which corresponds to approximately 0,15 % of the bearing width, an axial displacement of approximately 12 % of the bearing width is possible. Thus, when an axial displacement of approximately $0,12 \times 104 = 12,5$ mm has taken place, the operational clearance will be zero.

It should be remembered that the distance between the dotted line and the curve represents the residual radial operating clearance in the bearing arrangement.

Diagram 1 also illustrates how it is possible, simply by axially displacing the bearing rings relative to each other, to achieve a given radial internal clearance in a CARB bearing.

Axial displacement in % of the bearing width as a function of radial operational clearance

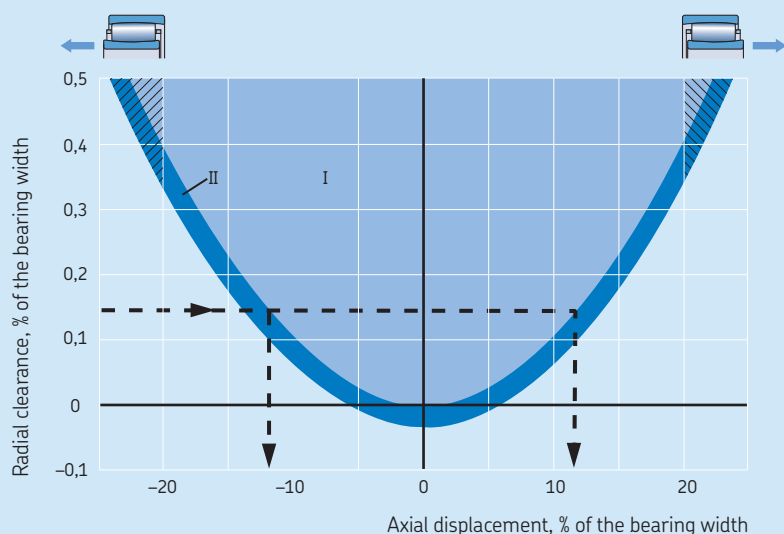

- I Range of operation with operational clearance
 II Possible range of operation where the bearing will have preload and the friction can increase by up to 50 % but where the L_{10} bearing life will still be achieved

Calculation example 1

For a C 3052 bearing having

- a width $B = 104$ mm
- a misalignment factor $k_1 = 0,122$
- a value for the axial displacement $s_1 = 19,3$,

with an angular misalignment of $\alpha = 0,3^\circ$ between the inner and outer rings, the permissible axial displacement can be obtained from

$$\begin{aligned} s_{lim} &= s_1 - s_{mis} \\ s_{lim} &= s_1 - k_1 B \alpha \\ s_{lim} &= 19,3 - 0,122 \times 104 \times 0,3 \\ s_{lim} &= 15,5 \text{ mm} \end{aligned}$$

Calculation example 2

For a C 3052 K/HA3C4 bearing having

- a width $B = 104$ mm
- an operating clearance factor $k_2 = 0,096$
- an operational clearance of 0,15 mm,

the possible axial displacement from the central position of one ring to the other until the operational clearance equals zero can be obtained from

$$\begin{aligned} s_{cle} &= \sqrt{\frac{B C_{red}}{k_2}} \\ s_{cle} &= \sqrt{\frac{104 \times 0,15}{0,096}} \end{aligned}$$

$$s_{cle} = 12,7 \text{ mm}$$

The axial displacement of 12,7 mm is below the limiting value $s_1 = 19,3$ mm, shown in the product table. An operating misalignment of $0,3^\circ$ is also permissible (\rightarrow Calculation example 1).

Calculation example 3

For a C 3052 bearing that has

- a width $B = 104$ mm
- an operating clearance factor $k_2 = 0,096$,

the reduction in operational clearance caused by an axial displacement $s_{cle} = 6,5$ mm from the central position is calculated using

$$\begin{aligned} C_{red} &= \frac{k_2 s_{cle}^2}{B} \\ C_{red} &= \frac{0,096 \times 6,5^2}{104} \end{aligned}$$

$$C_{red} = 0,039 \text{ mm}$$

Cages

Depending on their size, with the exception of full complement bearings, CARB bearings are fitted as standard with one of the following cages (→ fig. 6)

- an injection moulded window-type cage of glass fibre reinforced polyamide 4,6, roller centred, designation suffix TN9 (a)
- a pressed window-type steel cage, roller centred, no designation suffix (b)
- a machined window-type brass cage, roller centred, designation suffix M (c)
- a two-piece machined brass cage, inner ring centred, designation suffix MB (d).

Note

CARB bearings with polyamide 4,6 cages can be operated continuously at temperatures up to +130 °C. The lubricants generally used for rolling bearings do not have a detrimental effect on cage properties, with the exception of a few synthetic oils and greases with a synthetic oil base, and lubricants containing a high proportion of EP additives when used at high temperatures.

For bearing arrangements, which are to be operated at continuously high temperatures or under arduous conditions, SKF recommends using bearings with a steel or brass cage. Full complement bearings are another possible alternative.

For detailed information about temperature resistance and the applicability of cages, consult the SKF application engineering service.

Influence of operating temperature on bearing material

All CARB bearings undergo a special heat treatment so that they can be operated at higher temperatures for longer periods, without the occurrence of inadmissible dimensional changes, provided the permissible

operating temperature of the cage is not exceeded, for example, a temperature of +200 °C for 2 500 h, or for short periods at even higher temperatures.

Minimum load

To provide satisfactory operation, CARB bearings, like all ball and roller bearings, must always be subjected to a given minimum load, particularly if they are to operate at high speeds or are subjected to high accelerations or rapid changes in the direction of load. Under these conditions, the inertia forces of the rollers and cage, and the friction in the lubricant, can have a detrimental effect on the rolling conditions in the bearing arrangement and may cause damaging sliding movements to occur between the rollers and raceways.

The requisite minimum load to be applied to a CARB bearing with a cage can be estimated using

$$F_{rm} = 0,007 C_0$$

and for a full complement bearing using

$$F_{rm} = 0,01 C_0$$

where

F_{rm} = minimum radial bearing load, kN
 C_0 = basic static load rating, kN
 (→ product tables).

In some applications it is not possible to reach or exceed the requisite minimum load. However, for caged bearings that are oil lubricated, lower minimum loads are permissible. These loads can be calculated when $n/n_r \leq 0,3$ from

$$F_{rm} = 0,002 C_0$$

and when $0,3 < n/n_r \leq 2$ from

$$F_{rm} = 0,002 C_0 \left(1 + 2 \sqrt{\frac{n}{n_r} - 0,3} \right)$$

where

F_{rm} = minimum radial bearing load, kN

C_0 = basic static load rating, kN

(→ product tables)

n = rotational speed, r/min

n_r = reference speed, r/min

(→ product tables)

When starting up at low temperatures or when the lubricant is highly viscous, even greater minimum loads than $F_{rm} = 0,007 C_0$ and $0,01 C_0$ respectively may be required. The weight of the components supported by the bearing, together with external forces, generally exceeds the requisite minimum load. If this is not the case, the CARB bearing must be subjected to an additional radial load.

Equivalent dynamic bearing load

As the CARB bearing can only accommodate radial loads

$$P = F_r$$

Equivalent static bearing load

As the CARB bearing can only accommodate radial loads

$$P_0 = F_r$$

CARB bearings on adapter or withdrawal sleeves

CARB bearings with a tapered bore can be mounted on adapter or withdrawal sleeves. The sleeves enable the bearings to be quickly and easily secured on smooth or stepped shafts. Detailed information on CARB bearings

- on adapter sleeves can be found in the product table starting on **page 58**
- on withdrawal sleeves can be found in the product table starting on **page 68**.

Where appropriate, modified adapter sleeves of the E, L and TL designs, e.g. H 310 E, are available for CARB bearings to prevent the locking device from fouling the cage. With adapter sleeves of

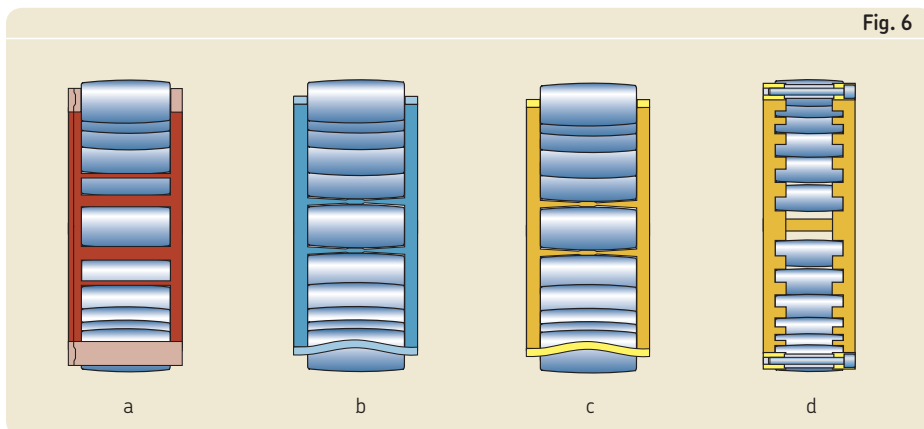

Fig. 6

Cages for CARB bearings

- H .. E series, the standard KM lock nut and MB locking washer are replaced by a KMFE lock nut (→ fig. 7)
- OH .. HE series, the standard HM lock nut is replaced by a HME nut with a changed front face (→ fig. 8)
- L-design, the standard KM lock nut and MB locking washer are replaced by a KML nut with an MBL locking washer; these have a lower sectional height (→ fig. 9)
- TL-design, the standard HM .. T lock nut and MB locking washer are replaced by a HM 30 nut with an MS 30 locking clip; these have a lower sectional height (→ fig. 10).

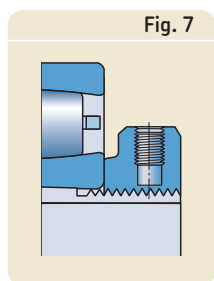

Fig. 7

H .. E series sleeve with a KMFE lock nut

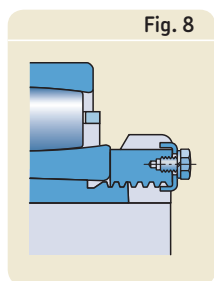

Fig. 8

OH .. HE series sleeve with a modified HME lock nut

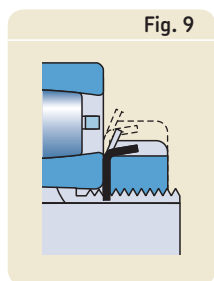

Fig. 9

H .. L series sleeve with a KML lock nut plus an MBL locking washer

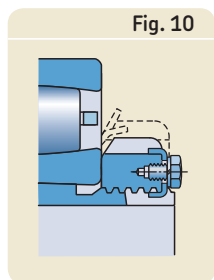

Fig. 10

OH .. HTL series sleeve with an HM 30 lock nut and an MS locking clip

Designation

The complete designation of a standard CARB toroidal roller bearing is made up of

- the prefix C
- the ISO dimension series identification
- the size identification
- any supplementary designations used to identify certain features of the bearing.

Diagram 2 shows the designation scheme and the meaning of the various letters and figures in the order in which they appear.

Diagram 2

Designation scheme for CARB toroidal roller bearings

Examples	C 2215 TN9/C3	C	22	15		TN9/C3
	C 3160 K/HA3C4	C	31	60	K/	HA3C4

Prefix

C Bearing with standardized dimensions
BSC- Special bearing

ISO dimension series

39, 49, 59, 69 ISO Diameter Series 9
30, 40, 50, 60 ISO Diameter Series 0
31, 41 ISO Diameter Series 1
22, 32 ISO Diameter Series 2
23 ISO Diameter Series 3

Size identification

05 × 5 25 mm bore diameter to
96 × 5 480 mm bore diameter from
/500 Bore diameter uncoded in millimetres

Bore

- Cylindrical bore
K Tapered bore, taper 1:12
K30 Tapered bore, taper 1:30

Other features

- Window-type steel cage, roller centred
- Normal radial internal clearance
C2 Radial internal clearance smaller than Normal
C3 Radial internal clearance greater than Normal
C4 Radial internal clearance greater than C3
C5 Radial internal clearance greater than C4
2CS Sheet steel reinforced acrylonitrile-butadiene rubber seal (NBR) on both sides of the bearing¹⁾
2CS5 Sheet steel reinforced hydrogenated acrylonitrile-butadiene rubber seal (HNBR) on both sides of the bearing²⁾
HA3 Case-hardened inner ring
M Window-type machined brass cage, roller centred
MB Machined brass cage, inner ring centred
2NS Highly efficient acrylonitrile-butadiene rubber seal on both sides of the bearing²⁾
TN9 Injection moulded cage of glass fibre reinforced polyamide 4,6, roller centred
V Full complement of rollers (no cage)
VE240 Bearing modified for greater axial displacement
VG114 Surface hardened pressed steel cage

¹⁾ Bearings with CS seals are filled with grease to 40 % of the free space in the bearing

²⁾ Bearings with CS5 seals as well as with NS seals are filled with grease to between 70 and 100 % of the free space in the bearing

CARB toroidal roller bearings

d 25 – 60 mm

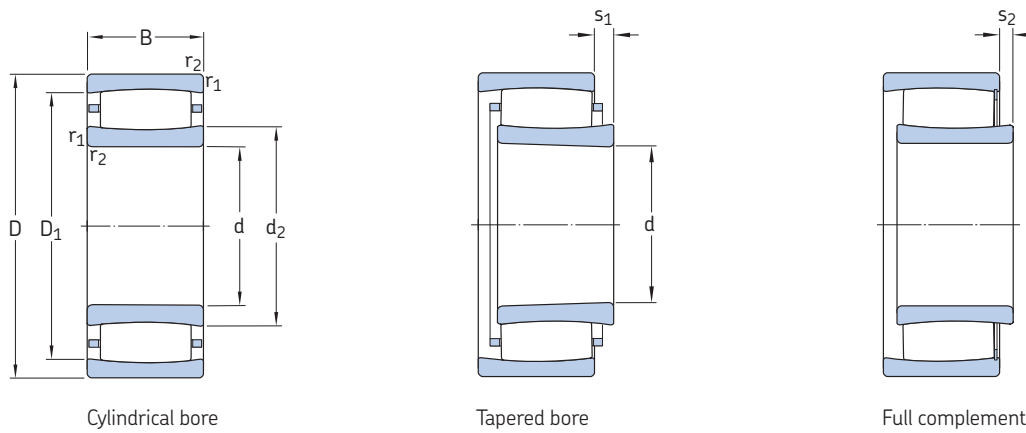

Principal dimensions			Basic load ratings		Fatigue load limit	Speed ratings		Mass	Designations	
d	D	B	dynamic	static		Reference speed	Limiting speed		Bearing with cylindrical bore	tapered bore
mm			C	C ₀	P _u	r/min		kg	–	
25	52	18	44	40	4,55	13 000	18 000	0,17	▶ C 2205 TN9	▶ C 2205 KTN9
	52	18	50	48	5,5	–	7 000	0,18	▶ C 2205 V	▶ C 2205 KV
30	55	45	134	180	19,6	–	3 000	0,50	C 6006 V	–
	62	20	69,5	62	7,2	11 000	15 000	0,27	C 2206 TN9	C 2206 KTN9
	62	20	76,5	71	8,3	–	6 000	0,29	C 2206 V	C 2206 KV
35	72	23	83	80	9,3	9 500	13 000	0,43	C 2207 TN9	C 2207 KTN9
	72	23	95	96,5	11,2	–	5 000	0,45	C 2207 V	C 2207 KV
40	62	22	76,5	100	11	–	4 300	0,25	C 4908 V	C 4908 K30V
	62	30	104	143	16	–	3 400	0,35	▶ C 5908 V	–
	62	40	122	180	19,3	–	2 800	0,47	▶ C 6908 V	–
	80	23	90	86,5	10,2	8 000	11 000	0,50	C 2208 TN9	C 2208 KTN9
	80	23	102	104	12	–	4 500	0,53	C 2208 V	C 2208 KV
45	68	22	81,5	112	12,9	–	3 800	0,30	▶ C 4909 V	▶ C 4909 K30V
	68	30	110	163	18,3	–	3 200	0,41	▶ C 5909 V	–
	68	40	132	200	22	–	2 600	0,55	▶ C 6909 V	–
	85	23	93	93	10,8	8 000	11 000	0,55	C 2209 TN9	C 2209 KTN9
	85	23	106	110	12,9	–	4 300	0,58	C 2209 V	C 2209 KV
50	72	22	86,5	125	13,7	–	3 600	0,29	C 4910 V	C 4910 K30V
	72	30	118	180	20,4	–	2 800	0,42	▶ C 5910 V	–
	72	40	140	224	24,5	–	2 200	0,54	C 6910 V	–
50	80	30	116	140	16	5 000	7 500	0,55	C 4010 TN9	C 4010 K30TN9
	80	30	137	176	20	–	3 000	0,59	C 4010 V	C 4010 K30V
	90	23	98	100	11,8	7 000	9 500	0,59	C 2210 TN9	C 2210 KTN9
	90	23	114	122	14,3	–	3 800	0,62	C 2210 V	C 2210 KV
	55	80	25	106	153	18	–	3 200	0,43	▶ C 4911 V
80		34	143	224	25	–	2 600	0,60	▶ C 5911 V	–
80		45	180	300	32,5	–	2 000	0,81	▶ C 6911 V	–
100		25	116	114	13,4	6 700	9 000	0,79	C 2211 TN9	C 2211 KTN9
100		25	132	134	16	–	3 400	0,81	C 2211 V	C 2211 KV
60	85	25	112	170	19,6	–	3 000	0,46	▶ C 4912 V	▶ C 4912 K30V
	85	34	150	240	26,5	–	2 400	0,64	▶ C 5912 V	–
	85	45	190	335	36	–	1 900	0,84	C 6912 V	–
	110	28	143	156	18,3	5 600	7 500	1,10	C 2212 TN9	C 2212 KTN9
	110	28	166	190	22,4	–	2 800	1,15	C 2212 V	C 2212 KV

▶ Please check availability of the bearing before incorporating it in a bearing arrangement design

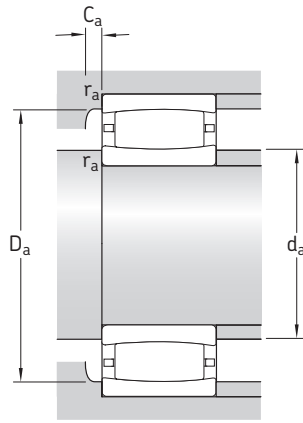

Dimensions			Abutment and fillet dimensions							Calculation factors			
d	d ₂ ≈	D ₁ ≈	r _{1,2} min	s ₁ ¹⁾ ≈	s ₂ ¹⁾ ≈	d _a min	d _a ²⁾ max	D _a ³⁾ min	D _a max	C _a ⁴⁾ min	r _a max	k ₁	k ₂
mm						mm				-			
25	32,1	43,3	1	5,8	-	30,6	32	42	46,4	0,3	1	0,09	0,126
	32,1	43,3	1	5,8	2,8	30,6	39	-	46,4	-	1	0,09	0,126
30	38,5	47,3	1	7,9	4,9	35,6	43	-	49,4	-	1	0,102	0,096
	37,4	53,1	1	4,5	-	35,6	37	51	56,4	0,3	1	0,101	0,111
	37,4	53,1	1	4,5	1,5	35,6	49	-	56,4	-	1	0,101	0,111
35	44,8	60,7	1,1	5,7	-	42	44	59	65	0,1	1	0,094	0,121
	44,8	60,7	1,1	5,7	2,7	42	57	-	65	-	1	0,094	0,121
40	46,1	55,3	0,6	4,7	1,7	43,2	52	-	58,8	-	0,6	0,099	0,114
	45,8	54,6	0,6	5	2	43,2	45	-	58,8	-	0,6	0,096	0,106
	46,6	53,8	0,6	9,4	6,4	43,2	46	-	58,8	-	0,6	0,113	0,088
	52,4	69,9	1,1	7,1	-	47	52	68	73	0,3	1	0,093	0,128
	52,4	69,9	1,1	7,1	4,1	47	66	-	73	-	1	0,093	0,128
45	51,6	60,5	0,6	4,7	1,7	48,2	51	-	64,8	-	0,6	0,114	0,1
	51,3	60,1	0,6	5	2	48,2	51	-	64,8	-	0,6	0,096	0,108
	52,1	59,3	0,6	9,4	6,4	48,2	52	-	64,8	-	0,6	0,113	0,09
	55,6	73,1	1,1	7,1	-	52	55	71	78	0,3	1	0,095	0,128
	55,6	73,1	1,1	7,1	4,1	52	69	-	78	-	1	0,095	0,128
50	56,9	66,1	0,6	4,7	1,7	53,2	62	-	68,8	-	0,6	0,103	0,114
	56,8	65,7	0,6	5	2	53,2	56	-	68,8	-	0,6	0,096	0,11
	57,5	65	0,6	9,4	6,4	53,2	61	-	68,8	-	0,6	0,093	0,113
	57,6	70,8	1	6	-	54,6	57	70	75,4	0,1	1	0,103	0,107
	57,6	70,8	1	6	3	54,6	67	-	75,4	-	1	0,103	0,107
	61,9	79,4	1,1	7,1	-	57	61	77	83	0,8	1	0,097	0,128
	61,9	79,4	1,1	7,1	3,9	57	73	-	83	-	1	0,097	0,128
	61,9	79,4	1,1	7,1	3,9	57	73	-	83	-	1	0,097	0,128
55	62	72,1	1	5,5	2,5	59,6	62	-	80,4	-	1	0,107	0,105
	62,8	72,4	1	6	3	59,6	62	-	80,4	-	1	0,097	0,109
	62,8	71,3	1	7,9	4,9	59,6	62	-	80,4	-	1	0,096	0,105
	65,8	86,7	1,5	8,6	-	64	65	84	91	0,3	1,5	0,094	0,133
	65,8	86,7	1,5	8,6	5,4	64	80	-	91	-	1,5	0,094	0,133
60	68	78,2	1	5,5	2,3	64,6	68	-	80,4	-	1	0,107	0,108
	66,8	76,5	1	6	2,8	64,6	66	-	80,4	-	1	0,097	0,11
	68,7	77,5	1	7,9	4,7	64,6	72	-	80,4	-	1	0,108	0,096
	77,1	97,9	1,5	8,5	-	69	77	95	101	0,3	1,5	0,1	0,123
	77,1	97,9	1,5	8,5	5,3	69	91	-	101	-	1,5	0,1	0,123

¹⁾ Permissible axial displacement from normal position of one bearing ring in relation to the other (→ page 40)

²⁾ To clear the cage for caged bearings or to clear the snap ring for full complement bearings

³⁾ To clear the cage for caged bearings

⁴⁾ Minimum width of free space for bearings with the cage in normal position (→ page 18)

CARB toroidal roller bearings

d 65 – 95 mm

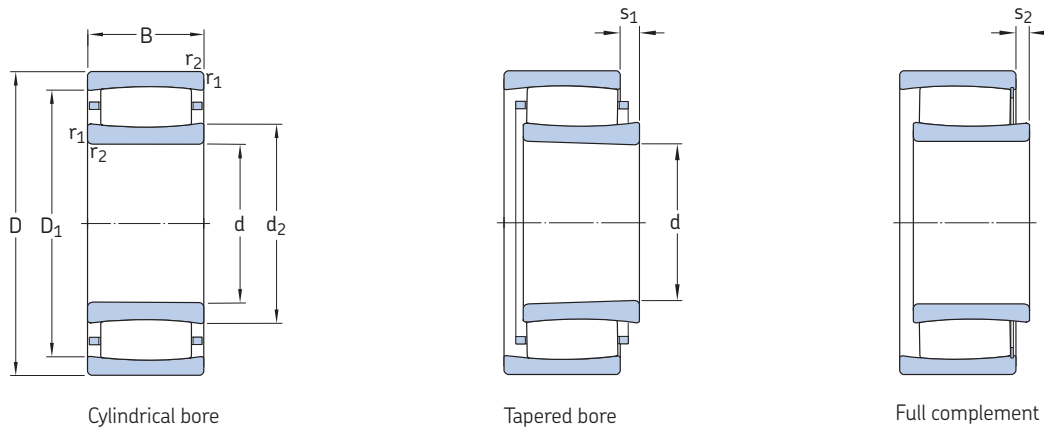

Principal dimensions			Basic load ratings		Fatigue load limit	Speed ratings		Mass	Designations	
d	D	B	dynamic	static		Reference speed	Limiting speed		Bearing with cylindrical bore	tapered bore
mm			C	C ₀	P _u	r/min		kg	–	
65	90	25	116	180	20,8	–	2 800	0,50	▶ C 4913 V	▶ C 4913 K30V
	90	34	156	260	30	–	2 200	0,70	▶ C 5913 V	–
	90	45	196	355	38	–	1 800	0,93	▶ C 6913 V	–
	100	35	196	275	32	–	2 400	1,00	▶ C 4013 V	▶ C 4013 K30V
	120	31	180	180	21,2	5 300	7 500	1,40	C 2213 TN9	C 2213 KTN9
	120	31	204	216	25,5	–	2 400	1,47	C 2213 V	C 2213 KV
70	100	30	163	240	28	–	2 600	0,78	▶ C 4914 V	▶ C 4914 K30V
	100	40	196	310	34,5	–	2 000	1,00	▶ C 5914 V	–
	100	54	265	455	49	–	1 700	1,40	▶ C 6914 V	–
	125	31	186	196	23,2	5 000	7 000	1,45	C 2214 TN9	C 2214 KTN9
	125	31	212	228	27	–	2 400	1,50	C 2214 V	C 2214 KV
	150	51	405	430	49	3 800	5 000	4,25	C 2314	C 2314 K
75	105	30	166	255	30	–	2 400	0,82	▶ C 4915 V	▶ C 4915 K30V
	105	40	204	325	37,5	–	1 900	1,10	C 5915 V	–
	105	54	204	325	37,5	–	1 600	1,40	C 6915 V/VE240	–
	115	40	208	345	40,5	–	2 000	1,60	C 4015 V	C 4015 K30V
	130	31	196	208	25,5	4 800	6 700	1,60	C 2215	C 2215 K
	130	31	220	240	29	–	2 200	1,65	C 2215 V	C 2215 KV
	160	55	425	465	52	3 600	4 800	5,20	C 2315	C 2315 K
80	110	30	173	275	31,5	–	2 200	0,87	▶ C 4916 V	▶ C 4916 K30V
	110	40	208	345	40	–	1 800	1,20	▶ C 5916 V	–
	140	33	220	250	28,5	4 500	6 000	2,00	C 2216	C 2216 K
	140	33	255	305	34,5	–	2 000	2,10	C 2216 V	C 2216 KV
	170	58	510	550	61	3 400	4 500	6,20	C 2316	C 2316 K
85	120	35	224	355	40,5	–	2 000	1,30	▶ C 4917 V	▶ C 4917 K30V
	120	46	275	465	52	–	1 700	1,70	▶ C 5917 V	–
	150	36	275	320	36,5	4 300	5 600	2,60	C 2217	C 2217 K
	150	36	315	390	44	–	1 800	2,80	▶ C 2217 V	▶ C 2217 KV
	180	60	540	600	65,5	3 200	4 300	7,30	C 2317	C 2317 K
90	125	35	186	315	35,5	–	2 000	1,30	▶ C 4918 V	▶ C 4918 K30V
	125	46	224	400	44	–	1 600	1,75	C 5918 V	–
	150	72	455	670	73,5	–	1 500	5,10	BSC-2039 V	–
	160	40	325	380	42,5	3 800	5 300	3,30	C 2218	C 2218 K
	160	40	365	440	49	–	1 500	3,40	▶ C 2218 V	▶ C 2218 KV
	190	64	610	695	73,5	2 800	4 000	8,50	C 2318	C 2318 K
95	170	43	360	400	44	3 800	5 000	4,00	▶ C 2219	▶ C 2219 K
	200	67	610	695	73,5	2 800	4 000	10,0	C 2319	C 2319 K

▶ Please check availability of the bearing before incorporating it in a bearing arrangement design

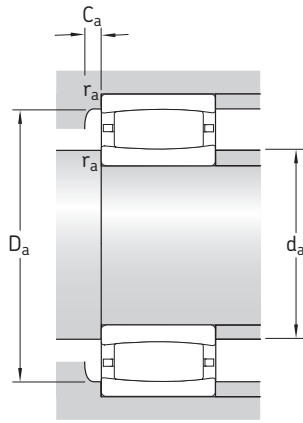

Dimensions			Abutment and fillet dimensions							Calculation factors			
d	d ₂ ≈	D ₁ ≈	r _{1,2} min	s ₁ ¹⁾ ≈	s ₂ ¹⁾ ≈	d _a min	d _a ²⁾ max	D _a ³⁾ min	D _a max	C _a ⁴⁾ min	r _a max	k ₁	k ₂
mm						mm				-			
65	72,1	82,2	1	5,5	2,3	69,6	72	-	85,4	-	1	0,107	0,109
	72,9	82,6	1	6	2,8	69,6	72	-	85,4	-	1	0,097	0,111
	72,9	81,4	1	7,9	4,7	69,6	72	-	85,4	-	1	0,096	0,107
	74,2	89,1	1,1	6	2,8	71	74	-	94	-	1	0,1	0,108
	79	106	1,5	9,6	-	74	79	102	111	0,2	1,5	0,097	0,127
	79	106	1,5	9,6	5,3	74	97	-	111	-	1,5	0,097	0,127
70	78	91	1	6	2,8	74,6	78	-	95,4	-	1	0,107	0,107
	78,7	90,3	1	9,4	6,2	74,6	78	-	95,4	-	1	0,114	0,095
	79,1	89,8	1	9	5,8	74,6	79	-	95,4	-	1	0,102	0,1
	83,7	111	1,5	9,6	-	79	83	107	116	0,4	1,5	0,098	0,127
	83,7	111	1,5	9,6	5,3	79	102	-	116	-	1,5	0,098	0,127
	91,4	130	2,1	9,1	-	82	105	120	138	2,2	2	0,11	0,099
75	83,1	96,1	1	6	2,8	79,6	83	-	100	-	1	0,107	0,108
	83,6	95,5	1	9,4	6,2	79,6	89	-	100	-	1	0,098	0,114
	83,6	95,5	1	9,2	9,2	79,6	88	-	100	-	1	0,073	0,154
	88,7	101	1,1	9,4	5,1	81	94	90	109	-	1	0,099	0,114
	88,5	115	1,5	9,6	-	84	98	110	121	1,2	1,5	0,099	0,127
	88,5	115	1,5	9,6	5,3	84	105	-	121	-	1,5	0,099	0,127
	98,5	135	2,1	13,1	-	87	110	130	148	2,2	2	0,103	0,107
	80	88,2	101	1	6	1,7	84,6	88	-	105	-	1	0,107
88,8	101	1	9,4	5,1	84,6	88	-	105	-	1	0,114	0,098	
98,1	125	2	9,1	-	91	105	120	129	1,2	2	0,104	0,121	
98,1	125	2	9,1	4,8	91	115	-	129	-	2	0,104	0,121	
102	145	2,1	10,1	-	92	115	135	158	2,4	2	0,107	0,101	
85	94,5	109	1,1	6	1,7	91	94	-	114	-	1	0,1	0,114
	95	109	1,1	8,9	4,6	91	95	-	114	-	1	0,098	0,109
	104	133	2	7,1	-	96	110	125	139	1,3	2	0,114	0,105
	104	133	2	7,1	1,7	96	115	-	139	-	2	0,114	0,105
	110	153	3	12,1	-	99	125	145	166	2,4	2,5	0,105	0,105
90	102	113	1,1	11	6,7	96	100	-	119	-	1	0,125	0,098
	102	113	1,1	15,4	11,1	96	105	-	119	-	1	0,089	0,131
	109	131	2	19,7	19,7	101	115	-	139	-	2	0,087	0,123
	112	144	2	9,5	-	101	120	130	149	1,4	2	0,104	0,117
	112	144	2	9,5	5,4	101	125	-	149	-	2	0,104	0,117
	119	166	3	9,6	-	104	135	155	176	2	2,5	0,108	0,101
95	113	149	2,1	10,5	-	107	112	149	158	4,2	2	0,114	0,104
	120	166	3	12,6	-	109	135	155	186	2,1	2,5	0,103	0,106

¹⁾ Permissible axial displacement from normal position of one bearing ring in relation to the other (→ page 40)

²⁾ To clear the cage for caged bearings or to clear the snap ring for full complement bearings

³⁾ To clear the cage for caged bearings

⁴⁾ Minimum width of free space for bearings with the cage in normal position (→ page 18)

CARB toroidal roller bearings

d 100 – 150 mm

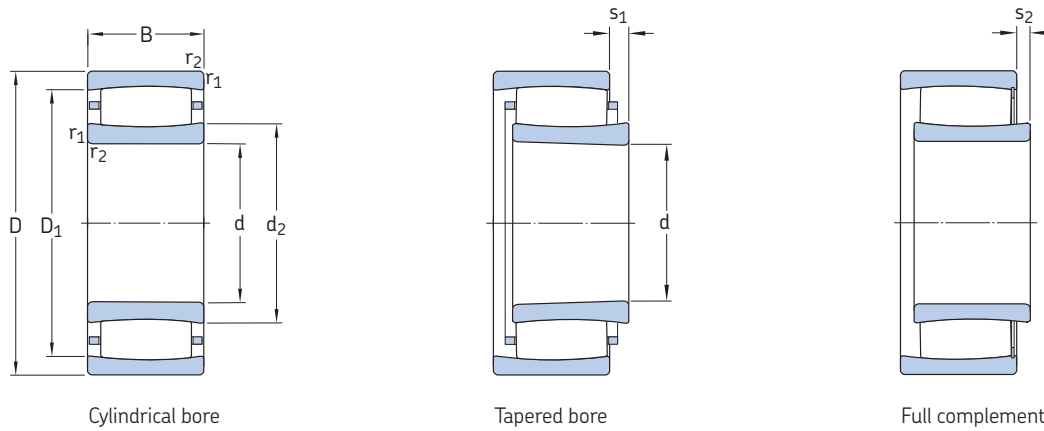

Principal dimensions			Basic load ratings		Fatigue load limit	Speed ratings		Mass	Designations		
d	D	B	dynamic	static		Reference speed	Limiting speed		Bearing with cylindrical bore	tapered bore	
mm			C	C ₀	P _u	r/min		kg	–		
100	140	40	275	450	49	–	1 700	1,90	▶ C 4920 V	▶ C 4920 K30V	
	140	54	375	640	68	–	1 400	2,70	▶ C 5920 V	–	
	150	50	355	530	57	–	1 400	3,05	C 4020 V	C 4020 K30V	
	150	67	510	865	90	–	1 100	4,30	C 5020 V	–	
	165	52	475	655	71	–	1 300	4,40	C 3120 V	–	
	165	65	475	655	71	–	1 300	5,25	C 4120 V/VE240	C 4120 K30V/VE240	
	170	65	475	655	71	–	1 400	5,95	BSC-2034 V	–	
	180	46	415	465	47,5	3 600	4 800	4,85	C 2220	C 2220 K	
	215	73	800	880	91,5	2 600	3 600	12,5	C 2320	C 2320 K	
	110	170	45	355	480	51	3 200	4 500	3,50	▶ C 3022	▶ C 3022 K
170		60	430	655	69,5	2 600	3 400	5,30	C 4022 MB	C 4022 K30MB	
170		60	500	800	85	–	1 200	5,20	C 4022 V	C 4022 K30V	
180		69	670	1 000	102	–	900	7,05	C 4122 V	C 4122 K30V	
200		53	530	620	64	3 200	4 300	6,90	C 2222	C 2222 K	
120		180	46	375	530	55	3 000	4 000	3,90	▶ C 3024	▶ C 3024 K
	180	46	430	640	67	–	1 400	4,05	C 3024 V	C 3024 KV	
	180	60	430	640	65,5	–	1 400	5,05	C 4024 V/VE240	C 4024 K30V/VE240	
	180	60	530	880	90	–	1 100	5,50	C 4024 V	C 4024 K30V	
	200	80	780	1 120	114	–	750	10,5	▶ C 4124 V	▶ C 4124 K30V	
	215	58	610	710	72	3 000	4 000	8,60	▶ C 2224	▶ C 2224 K	
	215	76	750	980	98	2 400	3 200	11,5	C 3224	C 3224 K	
	130	200	52	390	585	58,5	2 800	3 800	5,90	▶ C 3026	▶ C 3026 K
		200	69	620	930	91,5	1 900	2 800	7,84	C 4026	C 4026 K30
200		69	720	1 120	112	–	850	8,05	C 4026 V	C 4026 K30V	
210		80	750	1 100	108	–	670	10,5	C 4126 V/VE240	C 4126 K30V/VE240	
230		64	735	930	93	2 800	3 800	11,0	C 2226	C 2226 K	
140		210	53	490	735	72	2 600	3 400	6,30	▶ C 3028	▶ C 3028 K
	210	69	750	1 220	118	–	800	8,55	C 4028 V	C 4028 K30V	
	225	85	1 000	1 600	153	–	630	14,2	C 4128 V	C 4128 K30V	
	250	68	830	1 060	102	2 400	3 400	13,8	C 2228	C 2228 K	
	150	225	56	540	850	83	2 400	3 200	8,30	▶ C 3030 MB	▶ C 3030 KMB
225		56	585	960	93	–	1 000	8,00	C 3030 V	C 3030 KV	
225		75	780	1 320	125	–	750	10,5	C 4030 V	C 4030 K30V	
250		80	880	1 290	122	2 000	2 800	15,0	C 3130	C 3130 K	
250		100	1 220	1 860	173	–	450	20,5	▶ C 4130 V	▶ C 4130 K30V	
270		73	980	1 220	116	2 400	3 200	17,5	C 2230	C 2230 K	

▶ Please check availability of the bearing before incorporating it in a bearing arrangement design

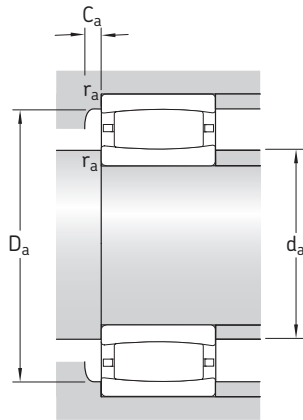

Dimensions			Abutment and fillet dimensions								Calculation factors		
d	d ₂ ≈	D ₁ ≈	r _{1,2} min	s ₁ ¹⁾ ≈	s ₂ ¹⁾ ≈	d _a min	d _a ²⁾ max	D _a ³⁾ min	D _a max	C _a ⁴⁾ min	r _a max	k ₁	k ₂
mm						mm				-			
100	113	130	1,1	9,4	5,1	106	110	-	134	-	1	0,115	0,103
	110	127	1,1	9	4,7	106	105	-	134	-	1	0,103	0,105
	113	135	1,5	14	9,7	109	120	-	141	-	1,5	0,098	0,118
	114	136	1,5	9,3	5	109	125	-	141	-	1,5	0,112	0,094
	119	150	2	10	4,7	111	130	-	154	-	2	0,1	0,112
	120	148	2	17,7	17,7	111	130	-	154	-	2	0,09	0,125
	120	148	2	17,7	17,7	111	130	-	159	-	2	0,09	0,125
	118	157	2,1	10,1	-	112	130	150	168	0,9	2	0,108	0,11
	126	185	3	11,2	-	114	150	170	201	3,2	2,5	0,113	0,096
	110	128	156	2	9,5	-	119	127	157	161	4	2	0,107
126		150	2	4,8	-	120	125	146	160	1,3	2	-	0,103
126		150	2	12	6,6	120	136	129	160	-	2	0,107	0,103
132		163	2	11,4	4,6	120	145	-	170	-	2	0,111	0,097
132		176	2,1	11,1	-	122	150	165	188	1,9	2	0,113	0,103
120	138	166	2	10,6	-	129	145	160	171	0,9	2	0,111	0,109
	138	166	2	10,6	3,8	129	150	-	171	-	2	0,111	0,109
	139	164	2	-	17,8	130	152	142	170	-	2	0,085	0,142
	140	164	2	12	5,2	129	150	-	171	-	2	0,109	0,103
	140	176	2	18	11,2	131	140	-	189	-	2	0,103	0,103
	144	191	2,1	13	-	132	143	192	203	5,4	2	0,113	0,103
	149	190	2,1	17,1	-	132	160	180	203	2,4	2	0,103	0,108
130	154	180	2	16,5	-	139	152	182	191	4,4	2	0,123	0,1
	149	181	2	11,4	-	139	155	175	191	1,9	2	0,113	0,097
	149	181	2	11,4	4,6	139	165	-	191	-	2	0,113	0,097
	153	190	2	9,7	9,7	141	170	-	199	-	2	0,09	0,126
	152	199	3	9,6	-	144	170	185	216	1,1	2,5	0,113	0,101
140	163	194	2	11	-	149	161	195	201	4,7	2	0,102	0,116
	161	193	2	11,4	5,9	149	175	-	201	-	2	0,115	0,097
	167	203	2,1	12	5,2	151	185	-	214	-	2	0,111	0,097
	173	223	3	13,7	-	154	190	210	236	2,3	2,5	0,109	0,108
150	173	204	2,1	8,7	-	161	172	200	214	1,3	2	-	0,108
	174	204	2,1	14,1	7,3	161	190	177	214	-	2	0,113	0,108
	173	204	2,1	17,4	10,6	161	185	-	214	-	2	0,107	0,106
	182	226	2,1	13,9	-	162	195	215	238	2,3	2	0,12	0,092
	179	222	2,1	20	10,1	162	175	-	228	-	2	0,103	0,103
	177	236	3	11,2	-	164	200	215	256	2,5	2,5	0,119	0,096

¹⁾ Permissible axial displacement from normal position of one bearing ring in relation to the other (→ page 40)

²⁾ To clear the cage for caged bearings or to clear the snap ring for full complement bearings

³⁾ To clear the cage for caged bearings

⁴⁾ Minimum width of free space for bearings with the cage in normal position (→ page 18)

CARB toroidal roller bearings

d 160 – 300 mm

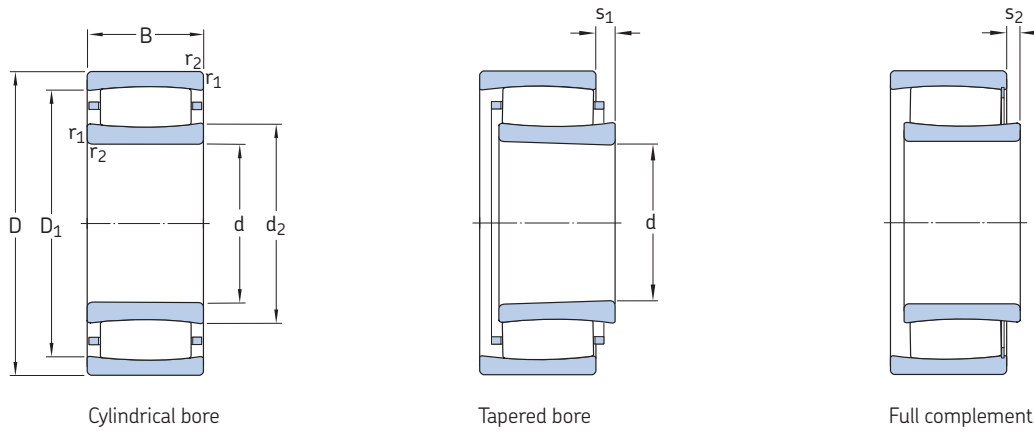

Principal dimensions			Basic load ratings		Fatigue load limit	Speed ratings		Mass	Designations	
d	D	B	C	C ₀		Reference speed	Limiting speed		Bearing with cylindrical bore	tapered bore
mm			kN		kN	r/min		kg	–	
160	240	60	600	980	93	2 200	3 000	9,60	▶ C 3032	▶ C 3032 K
	240	80	795	1 160	110	1 600	2 400	12,3	C 4032	C 4032 K30
	240	80	915	1 460	140	–	600	12,6	▶ C 4032 V	▶ C 4032 K30V
	270	86	1 000	1 400	129	1 900	2 600	21,5	C 3132 MB	C 3132 KMB
	270	109	1 460	2 160	200	–	300	26,0	▶ C 4132 V	▶ C 4132 K30V
	290	104	1 370	1 830	170	1 700	2 400	28,5	C 3232	C 3232 K
170	260	67	750	1 160	108	2 000	2 800	12,5	▶ C 3034	▶ C 3034 K
	260	90	1 140	1 860	170	–	500	17,5	C 4034 V	C 4034 K30V
	280	88	1 040	1 460	137	1 900	2 600	21,0	▶ C 3134	▶ C 3134 K
	280	109	1 530	2 280	208	–	280	27,0	▶ C 4134 V	▶ C 4134 K30V
	310	86	1 270	1 630	150	2 000	2 600	28,0	C 2234	C 2234 K
180	280	74	880	1 340	125	1 900	2 600	16,5	C 3036	C 3036 K ¹⁾
	280	100	1 320	2 120	193	–	430	23,0	C 4036 V	C 4036 K30V
	300	96	1 250	1 730	156	1 800	2 400	26,0	C 3136	C 3136 K ¹⁾
	300	118	1 760	2 700	240	–	220	34,5	▶ C 4136 V	▶ C 4136 K30V
	320	112	1 530	2 200	196	1 500	2 000	37,0	C 3236	C 3236 K
190	290	75	930	1 460	132	1 800	2 400	17,5	C 3038	C 3038 K ¹⁾
	290	100	1 370	2 320	204	–	380	24,5	▶ C 4038 V	▶ C 4038 K30V
	320	104	1 530	2 200	196	1 600	2 200	33,5	▶ C 3138	▶ C 3138 K
	320	128	2 040	3 150	275	–	130	43,0	▶ C 4138 V	▶ C 4138 K30V
	340	92	1 370	1 730	156	1 800	2 400	34,0	C 2238	C 2238 K ¹⁾
200	310	82	1 120	1 730	153	1 700	2 400	22,0	C 3040	C 3040 K ¹⁾
	310	109	1 630	2 650	232	–	260	30,5	C 4040 V	C 4040 K30V
	340	112	1 600	2 320	204	1 500	2 000	40,0	C 3140	C 3140 K ¹⁾
	340	140	2 360	3 650	315	–	80	54,0	▶ C 4140 V	▶ C 4140 K30V
220	340	90	1 320	2 040	176	1 600	2 200	29,0	C 3044	C 3044 K ¹⁾
	340	118	1 930	3 250	275	–	200	40,0	▶ C 4044 V	▶ C 4044 K30V
	370	120	1 900	2 900	245	1 400	1 900	51,0	C 3144	C 3144 K ¹⁾
	400	108	2 000	2 500	216	1 500	2 000	56,5	C 2244	C 2244 K ¹⁾
240	360	92	1 340	2 160	180	1 400	2 000	31,5	C 3048	C 3048 K ¹⁾
	400	128	2 320	3 450	285	1 300	1 700	63,0	C 3148	C 3148 K ¹⁾
260	400	104	1 760	2 850	232	1 300	1 800	46,0	C 3052	C 3052 K ¹⁾
	440	144	2 650	4 050	325	1 100	1 500	87,0	C 3152	C 3152 K ¹⁾
280	420	106	1 860	3 100	250	1 200	1 600	50,0	C 3056	C 3056 K ¹⁾
	460	146	2 850	4 500	355	1 100	1 400	93,0	C 3156	C 3156 K ¹⁾
300	460	118	2 160	3 750	290	1 100	1 500	71,0	C 3060 M	C 3060 KM
	460	160	2 900	4 900	380	850	1 200	95,0	▶ C 4060 M	▶ C 4060 K30M
	500	160	3 250	5 200	400	1 000	1 300	120	C 3160	C 3160 K ¹⁾
	500	200	4 150	6 700	520	750	1 000	165	C 4160 MB	C 4160 K30MB

▶ Please check availability of the bearing before incorporating it in a bearing arrangement design

¹⁾ Also available in design K/HA3C4

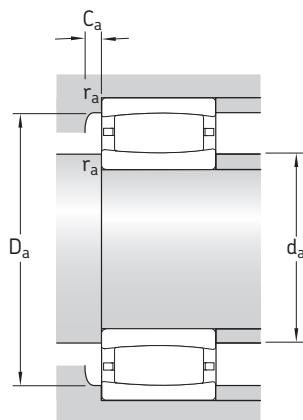

Dimensions			Abutment and fillet dimensions								Calculation factors		
d	d ₂ ≈	D ₁ ≈	r _{1,2} min	s ₁ ¹⁾ ≈	s ₂ ¹⁾ ≈	d _a min	d _a ²⁾ max	D _a ³⁾ min	D _a max	C _a ⁴⁾ min	r _a max	k ₁	k ₂
mm						mm				-			
160	187	218	2,1	15	-	171	186	220	229	5,1	2	0,115	0,106
	181	217	2,1	18,1	-	171	190	210	229	2,2	2	0,109	0,103
	181	217	2,1	18,1	8,2	171	195	-	229	-	2	0,109	0,103
	190	240	2,1	10,3	-	172	189	229	258	3,8	2	-	0,099
	190	241	2,1	21	11,1	172	190	-	258	-	2	0,101	0,105
194	256	3	19,3	-	174	215	245	276	2,6	2,5	0,112	0,096	
170	200	237	2,1	12,5	-	181	200	238	249	5,8	2	0,105	0,112
	195	235	2,1	17,1	7,2	181	215	-	249	-	2	0,108	0,103
	200	249	2,1	21	-	182	200	250	268	7,6	2	0,101	0,109
	200	251	2,1	21	11,1	182	200	-	268	-	2	0,101	0,106
	209	274	4	16,4	-	187	230	255	293	3	3	0,114	0,1
180	209	251	2,1	15,1	-	191	220	240	269	2	2	0,112	0,105
	203	247	2,1	20,1	10,2	191	225	-	269	-	2	0,107	0,103
	210	266	3	23,2	-	194	230	255	286	2,2	2,5	0,102	0,111
	211	265	3	20	10,1	194	210	-	286	-	2,5	0,095	0,11
	228	289	4	27,3	-	197	245	275	303	3,2	3	0,107	0,104
190	225	266	2,1	16,1	-	201	235	255	279	1,9	2	0,113	0,107
	220	263	2,1	20	10,1	201	220	-	279	-	2	0,103	0,106
	228	289	3	19	-	204	227	290	306	9,1	2,5	0,096	0,113
	222	284	3	20	10,1	204	220	-	306	-	2,5	0,094	0,111
	224	296	4	22,5	-	207	250	275	323	1,6	3	0,108	0,108
200	235	285	2,1	15,2	-	211	250	275	299	2,9	2	0,123	0,095
	229	280	2,1	21	11,1	211	225	-	299	-	2	0,11	0,101
	245	305	3	27,3	-	214	260	307	326	-	2,5	0,108	0,104
	237	302	3	22	12,1	214	235	-	326	-	2,5	0,092	0,112
220	257	310	3	17,2	-	233	270	295	327	3,1	2,5	0,114	0,104
	251	306	3	20	10,1	233	250	-	327	-	2,5	0,095	0,113
	268	333	4	22,3	-	237	290	315	353	3,5	3	0,114	0,097
	259	350	4	20,5	-	237	295	320	383	1,7	3	0,113	0,101
240	276	329	3	19,2	-	253	290	315	347	1,3	2,5	0,113	0,106
	281	357	4	20,4	-	257	305	335	383	3,7	3	0,116	0,095
260	305	367	4	19,3	-	275	325	350	385	3,4	3	0,122	0,096
	314	394	4	26,4	-	277	340	375	423	4,1	3	0,115	0,096
280	328	389	4	21,3	-	295	350	375	405	1,8	3	0,121	0,098
	336	416	5	28,4	-	300	360	395	440	4,1	4	0,115	0,097
300	352	417	4	20	-	315	375	405	445	1,7	3	0,123	0,095
	338	409	4	30,4	-	315	360	400	445	2,8	3	0,105	0,106
	362	448	5	30,5	-	320	390	425	480	4,9	4	0,106	0,106
	354	448	5	14,9	-	320	353	424	480	3,4	4	-	0,097

¹⁾ Permissible axial displacement from normal position of one bearing ring in relation to the other (→ page 40)

²⁾ To clear the cage for caged bearings or to clear the snap ring for full complement bearings

³⁾ To clear the cage for caged bearings

⁴⁾ Minimum width of free space for bearings with the cage in normal position (→ page 18)

CARB toroidal roller bearings

d 320 – 530 mm

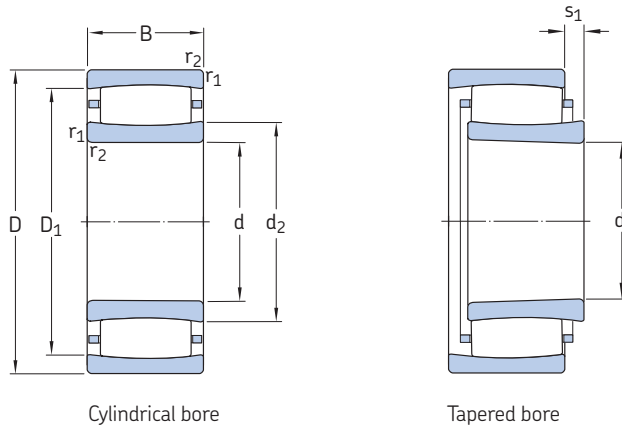

Principal dimensions			Basic load ratings		Fatigue load limit	Speed ratings		Mass	Designations	
d	D	B	dynamic	static		Reference speed	Limiting speed		Bearing with cylindrical bore	tapered bore
mm			kN		kN	r/min		kg	–	
320	480	121	2 280	4 000	310	1 000	1 400	76,5	C 3064 M	C 3064 KM
	540	176	4 150	6 300	480	950	1 300	160	C 3164 M	C 3164 KM
340	520	133	2 900	5 000	375	950	1 300	100	▶ C 3068 M	▶ C 3068 KM ¹⁾
	580	190	4 900	7 500	560	850	1 200	205	C 3168 M	C 3168 KM ¹⁾
360	480	90	1 760	3 250	250	1 000	1 400	44,0	C 3972 M	C 3972 KM
	540	134	2 900	5 000	375	900	1 200	105	▶ C 3072 M	▶ C 3072 KM ¹⁾
	600	192	5 000	8 000	585	800	1 100	215	C 3172 M	C 3172 KM ¹⁾
380	520	106	2 120	4 000	300	950	1 300	66	▶ C 3976 M	▶ C 3976 KM
	560	135	3 000	5 200	390	900	1 200	110	▶ C 3076 M	▶ C 3076 KM
	620	194	4 400	7 200	520	750	1 000	243	C 3176 MB	C 3176 KMB
400	540	106	2 120	4 000	290	900	1 300	68,5	▶ C 3980 M	▶ C 3980 KM
	600	148	3 650	6 200	450	800	1 100	140	▶ C 3080 M	▶ C 3080 KM
	650	200	4 800	8 300	585	700	950	260	C 3180 M	C 3180 KM
420	560	106	2 160	4 250	310	850	1 200	71,0	C 3984 M	C 3984 KM
	620	150	3 800	6 400	465	800	1 100	150	C 3084 M	C 3084 KM
	700	224	6 000	10 400	710	670	900	340	C 3184 M	C 3184 KM ¹⁾
440	600	118	2 600	5 300	375	800	1 100	99	▶ C 3988 M	▶ C 3988 KM
	650	157	3 750	6 400	465	750	1 000	185	C 3088 MB	C 3088 KMB
	720	226	6 700	11 400	780	630	850	385	C 3188 MB	C 3188 KMB
	720	280	7 500	12 900	900	500	670	471	C 4188 MB	C 4188 K30MB
460	620	118	2 700	5 300	375	800	1 100	100	▶ C 3992 MB	▶ C 3992 KMB
	680	163	4 000	7 500	510	700	950	200	C 3092 M	C 3092 KM ¹⁾
	760	240	6 800	12 000	800	600	800	430	C 3192 M	C 3192 KM
	760	300	8 300	14 300	950	480	630	535	C 4192 M	C 4192 K30M
480	650	128	3 100	6 100	430	750	1 000	120	C 3996 M	C 3996 KM
	700	165	4 050	7 800	530	670	900	210	C 3096 M	C 3096 KM
	790	248	6 950	12 500	830	560	750	490	▶ C 3196 MB	▶ C 3196 KMB
500	670	128	3 150	6 300	440	700	950	125	C 39/500 M	C 39/500 KM
	720	167	4 250	8 300	560	630	900	225	C 30/500 M	C 30/500 KM ¹⁾
	830	264	7 500	12 700	850	530	750	550	C 31/500 M	C 31/500 KM ¹⁾
	830	325	10 200	18 600	1 220	430	560	730	C 41/500 MB	C 41/500 K30MB
530	710	136	3 550	7 100	490	670	900	150	C 39/530 M	C 39/530 KM
	780	185	5 100	9 500	640	600	800	295	C 30/530 M	C 30/530 KM ¹⁾
	870	272	8 800	15 600	1 000	500	670	630	C 31/530 M	C 31/530 KM ¹⁾

▶ Please check availability of the bearing before incorporating it in a bearing arrangement design

¹⁾ Also available in design K/HA3C4

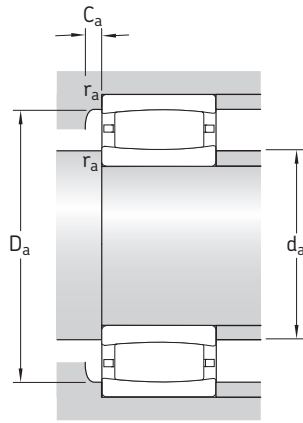

Dimensions					Abutment and fillet dimensions						Calculation factors	
d	d ₂ ≈	D ₁ ≈	r _{1,2} min	s ₁ ¹⁾ ≈	d _a min	d _a ²⁾ max	D _a ²⁾ min	D _a max	C _a ³⁾ min	r _a max	k ₁	k ₂
mm					mm						–	
320	376	440	4	23,3	335	395	430	465	1,8	3	0,121	0,098
	372	476	5	26,7	340	410	455	520	3,9	4	0,114	0,096
340	402	482	5	25,4	358	430	465	502	1,9	4	0,12	0,099
	405	517	5	25,9	360	445	490	560	4,2	4	0,118	0,093
360	394	450	3	17,2	373	405	440	467	1,6	2,5	0,127	0,104
	417	497	5	26,4	378	445	480	522	2	4	0,12	0,099
	423	537	5	27,9	380	460	510	522	3,9	4	0,117	0,094
380	428	489	4	21	395	450	475	505	1,8	3	0,129	0,098
	431	511	5	27	398	460	495	542	2	4	0,12	0,1
	446	551	5	25,4	400	445	526	600	7,3	4	–	0,106
400	439	501	4	21	415	461	487	525	1,8	3	0,13	0,098
	458	553	5	30,6	418	480	525	582	2,1	4	0,121	0,099
	488	589	6	50,7	426	526	564	624	2,5	5	0,106	0,109
420	462	522	4	21,3	435	480	515	545	1,8	3	0,132	0,098
	475	570	5	32,6	438	510	550	602	2,2	4	0,12	0,1
	508	618	6	34,8	446	540	595	674	3,8	5	0,113	0,098
440	494	560	4	20	455	517	546	585	1,9	3	0,133	0,095
	491	587	6	19,7	463	489	565	627	1,7	5	–	0,105
	522	647	6	16	466	521	613	694	7,5	5	–	0,099
	510	637	6	27,8	466	509	606	694	7,3	5	–	0,1
460	508	577	4	11	475	505	580	605	10,4	3	–	0,12
	539	624	6	33,5	486	565	605	654	2,3	5	0,114	0,108
	559	679	7,5	51	492	570	655	728	4,2	6	0,108	0,105
	540	670	7,5	46,2	492	570	655	728	5,6	6	0,111	0,097
480	529	604	5	20,4	498	550	590	632	2	4	0,133	0,095
	555	640	6	35,5	503	580	625	677	2,3	5	0,113	0,11
	583	700	7,5	24	512	580	705	758	20,6	6	–	0,104
500	556	631	5	20,4	518	580	615	652	2	4	0,135	0,095
	572	656	6	37,5	523	600	640	697	2,3	5	0,113	0,111
	605	738	7,5	75,3	532	655	705	798	–	6	0,099	0,116
	598	740	7,5	15	532	597	703	798	4,4	6	–	0,093
530	578	657	5	28,4	548	600	640	692	2,2	4	0,129	0,101
	601	704	6	35,7	553	635	685	757	2,5	5	0,12	0,101
	635	781	7,5	44,4	562	680	745	838	4,8	6	0,115	0,097

¹⁾ Permissible axial displacement from normal position of one bearing ring in relation to the other (→ page 40)

²⁾ To clear the cage

³⁾ Minimum width of free space for bearings with the cage in normal position (→ page 18)

CARB toroidal roller bearings

d 560 – 1 250 mm

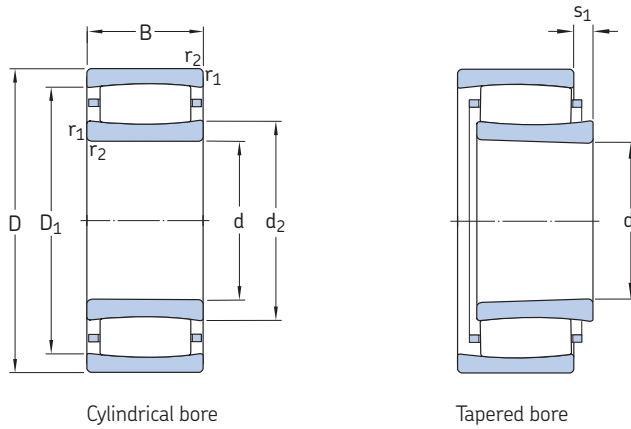

Principal dimensions			Basic load ratings		Fatigue load limit	Speed ratings		Mass	Designations	
d	D	B	dynamic	static		Reference speed	Limiting speed		Bearing with cylindrical bore	tapered bore
mm			kN		kN	r/min		kg	–	
560	750	140	3 600	7 350	490	600	850	170	C 39/560 M	C 39/560 KM
	820	195	5 600	11 000	720	530	750	345	C 30/560 M	C 30/560 KM ¹⁾
	920	280	9 500	17 000	1 100	480	670	750	▶ C 31/560 MB	▶ C 31/560 KMB
600	800	150	4 000	8 800	570	560	750	210	C 39/600 M	C 39/600 KM
	870	200	6 300	12 200	780	500	700	390	C 30/600 M	C 30/600 KM ¹⁾
	980	300	10 200	18 000	1 140	430	600	929	C 31/600 MB	C 31/600 KMB
	980	375	12 900	23 200	1 460	340	450	1 150	▶ C 41/600 MB	▶ C 41/600 K30MB
630	850	165	4 650	10 000	640	530	700	270	C 39/630 M	C 39/630 KM
	920	212	6 800	12 900	830	480	670	465	C 30/630 M	C 30/630 KM ¹⁾
	1 030	315	11 800	20 800	1 290	400	560	1 089	C 31/630 MB	C 31/630 KMB
670	900	170	5 100	11 600	720	480	630	335	C 39/670 MB	C 39/670 KMB
	980	230	8 150	16 300	1 000	430	600	580	C 30/670 M	C 30/670 KM ¹⁾
	1 090	336	12 000	22 000	1 320	380	530	1 230	▶ C 31/670 MB	▶ C 31/670 KMB
710	950	180	6 000	12 500	780	450	630	355	C 39/710 M	C 39/710 KM
	1 030	236	8 800	17 300	1 060	400	560	645	C 30/710 M	C 30/710 KM
	1 030	315	10 600	21 600	1 290	320	430	860	C 40/710 M	C 40/710 K30M
	1 150	345	12 700	24 000	1 430	360	480	1 410	▶ C 31/710 MB	▶ C 31/710 KMB
750	1 000	185	6 100	13 400	815	430	560	405	C 39/750 M	C 39/750 KM
	1 090	250	9 500	19 300	1 160	380	530	838	C 30/750 MB	C 30/750 KMB
	1 220	365	13 700	30 500	1 800	320	450	1 802	C 31/750 MB	C 31/750 KMB
800	1 060	195	5 850	15 300	915	380	530	504	▶ C 39/800 MB	▶ C 39/800 KMB
	1 150	258	9 150	18 600	1 120	360	480	860	C 30/800 MB	C 30/800 KMB
	1 280	375	15 600	30 500	1 760	300	400	1 870	▶ C 31/800 MB	▶ C 31/800 KMB
850	1 120	200	7 350	16 300	965	360	480	530	C 39/850 M	C 39/850 KM
	1 220	272	11 600	24 500	1 430	320	450	1 105	C 30/850 MB	C 30/850 KMB
	1 360	400	16 000	32 000	1 830	280	380	2 260	▶ C 31/850 MB	▶ C 31/850 KMB
900	1 180	206	8 150	18 000	1 060	340	450	580	▶ C 39/900 MB	▶ C 39/900 KMB
	1 280	280	12 700	26 500	1 530	300	400	1 200	C 30/900 MB	C 30/900 KMB
950	1 250	224	9 300	22 000	1 250	300	430	784	▶ C 39/950 MB	▶ C 39/950 KMB
	1 360	300	12 900	27 500	1 560	280	380	1 410	▶ C 30/950 MB	▶ C 30/950 KMB
1 000	1 420	308	13 400	29 000	1 630	260	340	1 570	▶ C 30/1000 MB	▶ C 30/1000 KMB
	1 580	462	22 800	45 500	2 500	220	300	3 470	▶ C 31/1000 MB	▶ C 31/1000 KMB
1 060	1 400	250	11 000	26 000	1 430	260	360	1 120	▶ C 39/1060 MB	▶ C 39/1060 KMB
1 180	1 540	272	13 400	33 500	1 800	220	300	1 400	C 39/1180 MB	C 39/1180 KMB
1 250	1 750	375	20 400	45 000	2 320	180	240	2 740	▶ C 30/1250 MB	▶ C 30/1250 KMB

▶ Please check availability of the bearing before incorporating it in a bearing arrangement design

¹⁾ Also available in design K/HA3C4

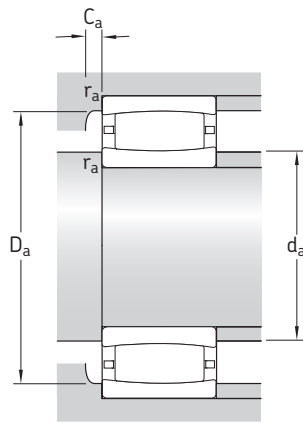

Dimensions					Abutment and fillet dimensions						Calculation factors	
d	d ₂ ≈	D ₁ ≈	r _{1,2} min	s ₁ ¹⁾ ≈	d _a min	d _a ²⁾ max	D _a ²⁾ min	D _a max	C _a ³⁾ min	r _a max	k ₁	k ₂
mm					mm						–	
560	622	701	5	32,4	578	645	685	732	2,3	4	0,128	0,104
	660	761	6	45,7	583	695	740	793	2,7	5	0,116	0,106
	664	808	7,5	28	592	660	810	888	23,8	6	–	0,111
600	666	744	5	32,4	618	685	725	782	2,4	4	0,131	0,1
	692	805	6	35,9	623	725	775	847	2,7	5	0,125	0,098
	705	871	7,5	26,1	632	704	827	948	5,1	6	–	0,107
	697	869	7,5	24,6	632	696	823	948	5,5	6	–	0,097
630	700	784	6	35,5	653	720	770	827	2,4	5	0,121	0,11
	717	840	7,5	48,1	658	755	810	892	2,9	6	0,118	0,104
	749	919	7,5	31	662	745	920	998	26,8	6	–	0,109
670	764	848	6	40,5	693	765	830	877	2,5	5	–	0,113
	775	904	7,5	41,1	698	820	875	952	2,9	6	0,121	0,101
	797	963	7,5	33	702	795	965	1 058	28	6	–	0,104
710	773	877	6	30,7	733	795	850	927	2,7	5	0,131	0,098
	807	945	7,5	47,3	738	850	910	1 002	3,2	6	0,119	0,104
	803	935	7,5	51,2	738	840	915	1 002	4,4	6	0,113	0,101
	848	1 012	9,5	34	750	845	1 015	1 100	28,6	8	–	0,102
750	830	933	6	35,7	773	855	910	977	2,7	5	0,131	0,101
	858	993	7,5	25	778	855	995	1 062	21,8	6	–	0,112
	888	1 076	9,5	36	790	885	1 080	1 180	31,5	8	–	0,117
800	889	990	6	45,7	823	915	970	1 037	2,9	5	–	0,106
	913	1 047	7,5	25	828	910	1 050	1 122	22,3	6	–	0,111
	947	1 133	9,5	37	840	945	1 135	1 240	32,1	8	–	0,115
850	940	1 053	6	35,9	873	960	1 025	1 097	2,9	5	0,135	0,098
	968	1 113	7,5	27	878	965	1 115	1 192	24,1	6	–	0,124
	1 020	1 200	12	40	898	1 015	1 205	1 312	33,5	10	–	0,11
900	989	1 113	6	20	923	985	1 115	1 157	18,4	5	–	0,132
	1 008	1 172	7,5	45,8	928	1 050	1 130	1 252	3,4	6	–	0,1
950	1 044	1 167	7,5	35	978	1 080	1 145	1 222	3,1	6	–	0,098
	1 080	1 240	7,5	30	978	1 075	1 245	1 322	26,2	6	–	0,116
1 000	1 136	1 294	7,5	30	1 028	1 135	1 295	1 392	26,7	6	–	0,114
	1 179	1 401	12	46	1 048	1 175	1 405	1 532	38,6	10	–	0,105
1 060	1 175	1 323	7,5	25	1 088	1 170	1 325	1 372	23,4	6	–	0,142
1 180	1 311	1 457	7,5	44,4	1 208	1 335	1 425	1 512	4,1	6	–	0,097
1 250	1 397	1 613	9,5	37	1 284	1 395	1 615	1 716	33,9	8	–	0,126

¹⁾ Permissible axial displacement from normal position of one bearing ring in relation to the other (→ page 40)

²⁾ To clear the cage

³⁾ Minimum width of free space for bearings with the cage in normal position (→ page 18)

Sealed CARB toroidal roller bearings
d 50 – 200 mm

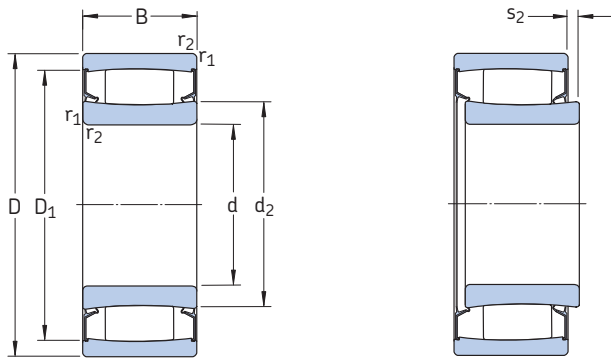

Principal dimensions			Basic load ratings		Fatigue load limit	Limiting speed	Mass	Designation
d	D	B	dynamic	static				
mm			C	C ₀	P _u	r/min	kg	–
50	72	40	140	224	24,5	200	0,56	▶ C 6910-2CS5V
60	85	45	150	240	26,5	170	0,83	▶ C 6912-2CS5V
	85	45	190	335	39	–	0,83	C 6912-2NSV
65	100	35	102	173	19	150	1,10	C 4013-2CS5V
75	105	54	204	325	37,5	140	1,40	C 6915-2CS5V
	115	40	143	193	23,2	130	1,40	▶ C 4015-2CS5V
90	125	46	224	400	44	110	1,75	C 5918-2CS5V
100	150	50	310	450	50	95	2,90	▶ C 4020-2CS5V
	165	65	475	655	71	90	5,20	C 4120-2CS5V
110	170	60	415	585	63	85	4,60	▶ C 4022-2CS5V
	170	60	500	800	85	–	5,20	C 4022-2NSV
	180	69	500	710	75	85	6,60	C 4122-2CS5V
120	180	60	430	640	67	80	5,10	C 4024-2CS5V
	200	80	710	1 000	100	75	9,70	▶ C 4124-2CS5V
130	200	69	550	830	85	70	7,50	C 4026-2CS5V
	210	80	750	1 100	108	70	10,5	C 4126-2CS5V
140	210	69	570	900	88	67	7,90	▶ C 4028-2CS5V
	225	85	780	1 200	116	63	12,5	C 4128-2CS5V
150	225	75	585	965	93	63	10,0	C 4030-2CS5V
	250	100	1 220	1 860	173	60	20,5	▶ C 4130-2CS5V
160	240	80	655	1 100	104	60	12,0	▶ C 4032-2CS5V
	270	109	1 460	2 160	200	53	26,0	▶ C 4132-2CS5V
170	260	90	965	1 630	150	53	17,0	▶ C 4034-2CS5V
	280	109	1 530	2 280	208	53	27,0	▶ C 4134-2CS5V
180	280	100	1 320	2 120	193	53	23,5	▶ C 4036-2CS5V
	300	118	1 760	2 700	240	48	35,0	▶ C 4136-2CS5V
190	290	100	1 370	2 320	204	48	24,5	▶ C 4038-2CS5V
	320	128	2 040	3 150	275	45	43,5	▶ C 4138-2CS5V
200	310	109	1 630	2 650	232	45	31,0	▶ C 4040-2CS5V
	340	140	2 360	3 650	315	43	54,5	▶ C 4140-2CS5V

▶ Please check availability of the bearing before incorporating it in a bearing arrangement design

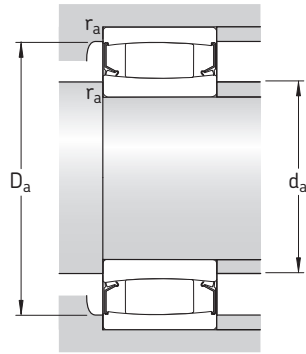

Dimensions

Abutment and fillet dimensions

Calculation factors

d	d ₂ ≈	D ₁ ≈	r _{1,2} min	s ₂ ¹⁾ ≈	d _a min	d _a ²⁾ max	D _a max	r _a max	k ₁	k ₂
mm					mm				-	
50	57,6	64,9	0,6	2,8	53,2	57	68,8	0,6	0,113	0,091
60	68 68,7	75,3 77,5	1 1	5,4 0,5	64,6 64,6	67 68,7	80,4 80,4	1 1	0,128 0,108	0,083 0,096
65	78,6	87,5	1,1	5,9	71	78	94	1	0,071	0,181
75	83,6 88,5	95,5 104	1 1,1	7,1 7,3	79,6 81	83 88	100 111	1 1	0,073 0,210	0,154 0,063
90	102	113	1,1	4,5	96	101	119	1	0,089	0,131
100	114 120	136 148	1,5 2	6,2 7,3	107 111	113 120	143 154	1,5 2	0,145 0,09	0,083 0,125
110	128 126 130	155 150 160	2 2 2	7,9 0,5 8,2	119 120 121	127 126 129	161 160 169	2 2 2	0,142 0,107 0,086	0,083 0,103 0,133
120	140 140	164 176	2 2	7,5 8,2	129 131	139 139	171 189	2 2	0,085 0,126	0,142 0,087
130	152 153	182 190	2 2	8,2 7,5	139 141	151 152	191 199	2 2	0,089 0,09	0,133 0,126
140	163 167	193 204	2 2,1	8,7 8,9	149 152	162 166	201 213	2 2	0,133 0,086	0,089 0,134
150	175 179	204 221	2,1 2,1	10,8 6,4	161 162	174 178	214 238	2 2	0,084 0,103	0,144 0,103
160	188 190	218 241	2,1 2,1	11,4 6,7	170 172	187 189	230 258	2 2	0,154 0,101	0,079 0,105
170	201 200	237 251	2,1 2,1	9 6,7	180 182	199 198	250 268	2 2	0,116 0,101	0,097 0,106
180	204 211	246 265	2,1 3	6,4 6,4	190 194	202 209	270 286	2 2,5	0,103 0,095	0,105 0,11
190	221 222	263 283	2,1 3	6,4 6,4	200 204	219 220	280 306	2 2,5	0,103 0,094	0,106 0,111
200	229 237	280 301	2,1 3	6,7 7	210 214	227 235	300 326	2 2,5	0,101 0,092	0,108 0,112

¹⁾ Permissible axial displacement from normal position of one bearing ring in relation to the other (→ page 40)

²⁾ To clear the seal

CARB toroidal roller bearings on an adapter sleeve

d_1 20 – 80 mm

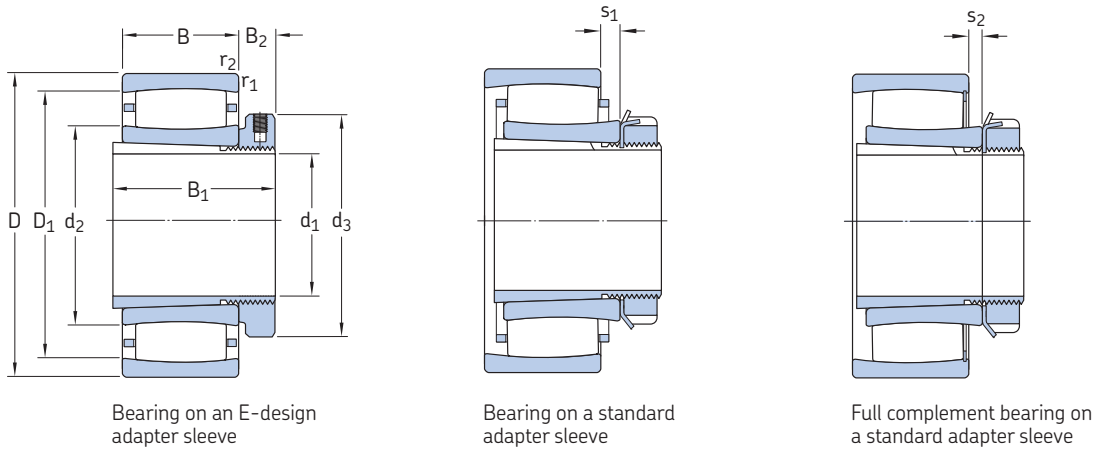

Principal dimensions			Basic load ratings		Fatigue load limit	Speed ratings		Mass Bearing + sleeve	Designations Bearing	Adapter sleeve
d_1	D	B	dynamic C	static C_0		Reference speed	Limiting speed			
mm			kN		kN	r/min	kg	–		
20	52	18	44	40	4,55	13 000	18 000	0,24 0,25	▶ C 2205 KTN9 ▶ C 2205 KV	H 305 E H 305 E
	52	18	50	48	5,5	–	7 000			
25	62	20	69,5	62	7,2	11 000	15 000	0,37 0,39	C 2206 KTN9 C 2206 KV	H 306 E H 306 E
	62	20	76,5	71	8,3	–	6 000			
30	72	23	83	80	9,3	9 500	13 000	0,59 0,59	C 2207 KTN9 C 2207 KV	H 307 E H 307 E
	72	23	95	96,5	11,2	–	5 000			
35	80	23	90	86,5	10,2	8 000	11 000	0,69 0,70	C 2208 KTN9 C 2208 KV	H 308 E H 308
	80	23	102	104	12	–	4 500			
40	85	23	93	93	10,8	8 000	11 000	0,76 0,79	C 2209 KTN9 C 2209 KV	H 309 E H 309 E
	85	23	106	110	12,9	–	4 300			
45	90	23	98	100	11,8	7 000	9 500	0,85 0,89	C 2210 KTN9 C 2210 KV	H 310 E H 310 E
	90	23	114	122	14,3	–	3 800			
50	100	25	116	114	13,4	6 700	9 000	1,10 1,15	C 2211 KTN9 C 2211 KV	H 311 E H 311 E
	100	25	132	134	16	–	3 400			
55	110	28	143	156	18,3	5 600	7 500	1,45 1,50	C 2212 KTN9 C 2212 KV	H 312 E H 312
	110	28	166	190	22,4	–	2 800			
60	120	31	180	180	21,2	5 300	7 500	1,80 1,90	C 2213 KTN9 C 2213 KV	H 313 E H 313
	120	31	204	216	25,5	–	2 400			
	125	31	186	196	23,2	5 000	7 000			
	125	31	212	228	27	–	2 400			
65	150	51	405	430	49	3 800	5 000	2,10 2,20 5,10	C 2214 KTN9 C 2214 KV C 2314 K	H 314 E H 314 H 2314
	130	31	196	208	25,5	4 800	6 700			
	130	31	220	240	29	–	2 200			
70	160	55	425	465	52	3 600	4 800	2,30 2,40 6,20	C 2215 KV C 2315 K	H 315 H 315 H 2315
	140	33	220	250	28,5	4 500	6 000			
	140	33	255	305	34,5	–	2 000			
75	170	58	510	550	61	3 400	4 500	2,90 3,00 7,40	C 2216 K C 2216 KV C 2316 K	H 316 E H 316 H 2316
	140	36	275	320	36,5	4 300	5 600			
	150	36	315	390	44	–	1 800			
80	180	60	540	600	65,5	3 200	4 300	3,70 3,85 8,50	▶ C 2217 K ▶ C 2217 KV C 2317 K	H 317 E H 317 H 2317
	150	40	325	380	42,5	3 800	5 300			
	160	40	365	440	49	–	1 500			
80	190	64	610	695	73,5	2 800	4 000	4,50 4,60 10,0	▶ C 2218 K ▶ C 2218 KV C 2318 K	H 318 E H 318 H 2318

▶ Please check availability of the bearing before incorporating it in a bearing arrangement design

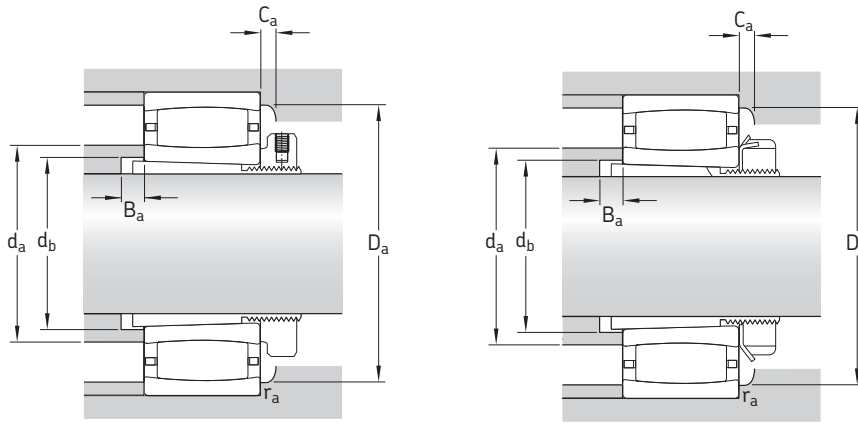

Dimensions

Abutment and fillet dimensions

Calculation factors

d ₁	d ₂ ≈	d ₃	D ₁ ≈	B ₁	B ₂	r _{1,2} min	s ₁ ¹⁾ ≈	s ₂ ¹⁾ ≈	d _a ²⁾ max	d _b min	D _a ³⁾ min	D _a max	B _a min	C _a ⁴⁾ min	r _a max	k ₁	k ₂
mm									mm						-		
20	32,1	38	43,3	29	10,5	1	5,8	-	32	28	42	46,4	5	0,3	1	0,09	0,126
	32,1	38	43,3	29	10,5	1	5,8	2,8	39	28	-	46,4	5	-	1	0,09	0,126
25	37,4	45	53,1	31	10,5	1	4,5	-	37	33	51	56,4	5	0,3	1	0,101	0,111
	37,4	45	53,1	31	10,5	1	4,5	1,5	49	33	-	56,4	5	-	1	0,101	0,111
30	44,8	52	60,7	35	11,5	1,1	5,7	-	44	39	59	65	5	0,1	1	0,094	0,121
	44,8	52	60,7	35	11,5	1,1	5,7	2,7	57	39	-	65	5	-	1	0,094	0,121
35	52,4	58	69,9	36	13	1,1	7,1	-	52	44	68	73	5	0,3	1	0,093	0,128
	52,4	58	69,9	36	10	1,1	7,1	4,1	66	44	-	73	5	-	1	0,093	0,128
40	55,6	65	73,1	39	13	1,1	7,1	-	55	50	71	78	7	0,3	1	0,095	0,128
	55,6	65	73,1	39	13	1,1	7,1	4,1	69	50	-	78	7	-	1	0,095	0,128
45	61,9	70	79,4	42	14	1,1	7,1	-	61	55	77	83	9	0,8	1	0,097	0,128
	61,9	70	79,4	42	14	1,1	7,1	3,9	73	55	-	83	9	-	1	0,097	0,128
50	65,8	75	86,7	45	14	1,5	8,6	-	65	60	84	91	10	0,3	1,5	0,094	0,133
	65,8	75	86,7	45	14	1,5	8,6	5,4	80	60	-	91	10	-	1,5	0,094	0,133
55	77,1	80	97,9	47	14	1,5	8,5	-	77	65	95	101	9	0,3	1,5	0,1	0,123
	77,1	80	97,9	47	12,5	1,5	8,5	5,3	91	65	-	101	9	-	1,5	0,1	0,123
60	79	85	106	50	15	1,5	9,6	-	79	70	102	111	8	0,2	1,5	0,097	0,127
	79	85	106	50	13,5	1,5	9,6	5,3	97	70	-	111	8	-	1,5	0,097	0,127
	83,7	92	111	52	15	1,5	9,6	-	83	75	107	116	9	0,4	1,5	0,098	0,127
	83,7	92	111	52	13,5	1,5	9,6	5,3	102	75	-	116	9	-	1,5	0,098	0,127
65	91,4	92	130	68	13,5	2,1	9,1	-	105	76	120	138	6	2,2	2	0,11	0,099
	88,5	98	115	55	16	1,5	9,6	-	98	80	110	121	12	1,2	1,5	0,099	0,127
	88,5	98	115	55	14,5	1,5	9,6	5,3	105	80	-	121	12	-	1,5	0,099	0,127
70	98,5	98	135	73	14,5	2,1	13,1	-	110	82	130	148	5	2,2	2	0,103	0,107
	98,1	105	125	59	18	2	9,1	-	105	85	120	129	12	1,2	2	0,104	0,121
	98,1	105	125	59	17	2	9,1	4,8	115	85	-	129	12	-	2	0,104	0,121
75	102	105	145	78	17	2,1	10,1	-	115	88	135	158	6	2,4	2	0,107	0,101
	104	110	133	63	19	2	7,1	-	110	91	125	139	12	1,3	2	0,114	0,105
	104	110	133	63	18	2	7,1	1,7	115	91	-	139	12	-	2	0,114	0,105
80	110	110	153	82	18	3	12,1	-	125	94	145	166	7	2,4	2,5	0,105	0,105
	112	120	144	65	19	2	9,5	-	120	96	130	149	10	1,4	2	0,104	0,117
	112	120	144	65	18	2	9,5	5,4	125	96	-	149	10	-	2	0,104	0,117
80	119	120	166	86	18	3	9,6	-	135	100	155	176	7	2	2,5	0,108	0,101

¹⁾ Permissible axial displacement from normal position of one bearing ring in relation to the other (→ page 40)

²⁾ To clear the cage for caged bearings or to clear the snap ring for full complement bearings

³⁾ To clear the cage for caged bearings

⁴⁾ Minimum width of free space for bearings with the cage in normal position (→ page 18)

CARB toroidal roller bearings on an adapter sleeve

d_1 85 – 180 mm

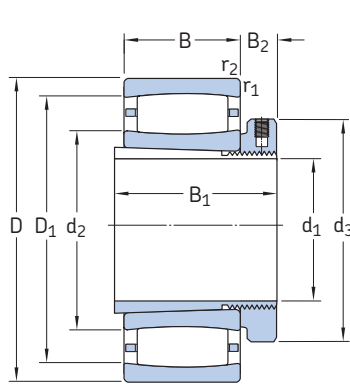

Bearing on an E-design adapter sleeve

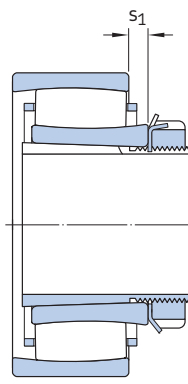

Bearing on a L-design or standard adapter sleeve

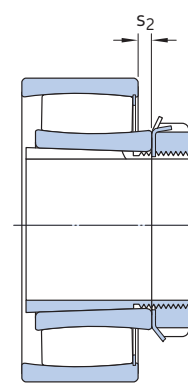

Full complement bearing on a standard adapter sleeve

Principal dimensions			Basic load ratings		Fatigue load limit	Speed ratings		Mass Bearing + sleeve	Designations Bearing	Adapter sleeve
d_1	D	B	dynamic	static		Reference speed	Limiting speed			
mm			C	C_0	P_u	r/min	kg	–		
85	170	43	360	400	44	3 800	5 000	5,30	▶ C 2219 K C 2319 K	H 319 E H 2319
	200	67	610	695	73,5	2 800	4 000	11,5		
90	165	52	475	655	71	–	1 300	6,10	C 3120 KV C 2220 K C 2320 K	H 3120 E H 320 E H 2320
	180	46	415	465	47,5	3 600	4 800	6,30		
	215	73	800	880	91,5	2 600	3 600	14,5		
100	170	45	355	480	51	3 200	4 500	5,50	C 3022 K C 2222 K	H 322 E H 322 E
	200	53	530	620	64	3 200	4 300	8,80		
110	180	46	375	530	55	3 000	4 000	5,70	▶ C 3024 K C 3024 KV ▶ C 2224 K C 3224 K	H 3024 E H 3024 H 3124 L H 2324 L
	180	46	430	640	67	–	1 400	5,85		
	215	58	610	710	72	3 000	4 000	8,60		
	215	76	750	980	98	2 400	3 200	14,2		
115	200	52	390	585	58,5	2 800	3 800	8,70	▶ C 3026 K C 2226 K	H 3026 H 3126 L
	230	64	735	930	93	2 800	3 800	14,0		
125	210	53	490	735	72	2 600	3 400	9,30	▶ C 3028 K C 2228 K	H 3028 H 3128 L
	250	68	830	1 060	102	2 400	3 400	17,5		
135	225	56	585	960	93	–	1 000	11,5	▶ C 3030 KV C 3030 KMB C 3130 K C 2230 K	H 3030 H 3030 E H 3130 L H 3130 L
	225	56	540	850	83	2 400	3 200	12,0		
	250	80	880	1 290	122	2 000	2 800	20,0		
	270	73	980	1 220	116	2 400	3 200	23,0		
140	240	60	600	980	93	2 200	3 000	14,5	▶ C 3032 K C 3132 KMB C 3232 K	H 3032 H 3132 E H 2332 L
	270	86	1 000	1 400	129	1 900	2 600	28,0		
	290	104	1 370	1 830	170	1 700	2 400	36,5		
150	260	67	750	1 160	108	2 000	2 800	18,0	▶ C 3034 K ▶ C 3134 K C 2234 K	H 3034 H 3134 L H 3134 L
	280	88	1 040	1 460	137	1 900	2 600	29,0		
	310	86	1 270	1 630	150	2 000	2 600	35,0		
160	280	74	880	1 340	125	1 900	2 600	23,0	C 3036 K C 3136 K C 3236 K	H 3036 H 3136 L H 2336
	300	96	1 250	1 730	156	1 800	2 400	34,0		
	320	112	1 530	2 200	196	1 500	2 000	47,0		
170	290	75	930	1 460	132	1 800	2 400	24,0	▶ C 3038 K ▶ C 3138 K C 2238 K	H 3038 H 3138 L H 3138
	320	104	1 530	2 200	196	1 600	2 200	44,0		
	340	92	1 370	1 730	156	1 800	2 400	43,0		
180	310	82	1 120	1 730	153	1 700	2 400	30,0	C 3040 K C 3140 K	H 3040 H 3140
	340	112	1 600	2 320	204	1 500	2 000	50,5		

▶ Please check availability of the bearing before incorporating it in a bearing arrangement design

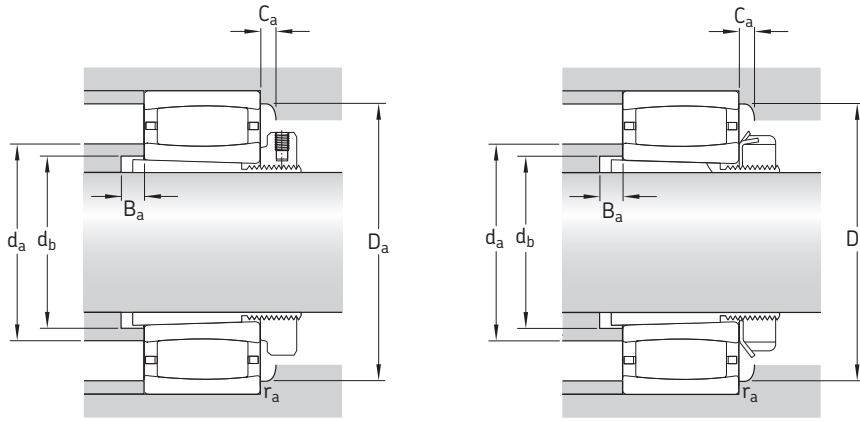

Dimensions									Abutment and fillet dimensions							Calculation factors	
d_1	d_2	d_3	D_1	B_1	B_2	$r_{1,2}$	$s_1^{1)}$	$s_2^{1)}$	$d_a^{2)}$	d_b	$D_a^{3)}$	D_a	B_a	$C_a^{4)}$	r_a	k_1	k_2
mm									mm							-	
85	113	125	149	68	20	2,1	10,5	-	112	102	149	158	9	4,2	2	0,114	0,104
	120	125	166	90	19	3	12,6	-	135	105	155	186	7	2,1	2,5	0,103	0,106
90	119	130	150	76	20	2	10	4,7	130	106	-	154	6	-	2	0,1	0,112
	118	130	157	71	21	2,1	10,1	-	130	108	150	168	8	0,9	2	0,108	0,11
	126	130	185	97	20	3	11,2	-	150	110	170	201	7	3,2	2,5	0,113	0,096
100	128	145	156	77	21,5	2	9,5	-	127	118	157	160	14	4	2	0,107	0,11
	132	145	176	77	21,5	2,1	11,1	-	150	118	165	188	6	1,9	2	0,113	0,103
110	138	155	166	72	26	2	10,6	-	145	127	160	170	7	0,9	2	0,111	0,109
	138	145	166	72	22	2	10,6	3,8	150	127	-	170	7	-	2	0,111	0,109
	144	145	191	88	22	2,1	13	-	143	128	192	203	11	5,4	2	0,113	0,103
	149	145	190	112	22	2,1	17,1	-	160	131	180	203	17	2,4	2	0,103	0,108
115	154	155	180	80	23	2	16,5	-	152	137	182	190	8	4,4	2	0,123	0,1
	152	155	199	92	23	3	9,6	-	170	138	185	216	8	1,1	2,5	0,113	0,101
125	163	165	194	82	24	2	11	-	161	147	195	200	8	4,7	2	0,102	0,116
	173	165	223	97	24	3	13,7	-	190	149	210	236	8	2,3	2,5	0,109	0,108
135	174	195	204	87	30	2,1	14,1	7,3	190	158	177	214	8	-	2	0,113	0,108
	173	180	204	87	26	2,1	8,7	-	172	158	200	214	8	1,3	2	-	0,108
	182	180	226	111	26	2,1	13,9	-	195	160	215	238	8	2,3	2	0,12	0,092
	177	180	236	111	26	3	11,2	-	200	160	215	256	15	2,5	2,5	0,119	0,096
140	187	190	218	93	27,5	2,1	15	-	186	168	220	229	8	5,1	2	0,115	0,106
	190	190	240	119	27,5	2,1	10,3	-	189	170	229	258	8	3,8	2	-	0,099
	194	190	256	147	27,5	3	19,3	-	215	174	245	276	18	2,6	2,5	0,112	0,096
150	200	200	237	101	28,5	2,1	12,5	-	200	179	238	249	8	5,8	2	0,105	0,112
	200	200	249	122	28,5	2,1	21	-	200	180	250	268	8	7,6	2	0,101	0,109
	209	200	274	122	28,5	4	16,4	-	230	180	255	293	10	3	3	0,114	0,1
160	209	210	251	109	29,5	2,1	15,1	-	220	189	240	269	8	2	2	0,112	0,105
	210	240	266	131	29,5	3	23,2	-	230	191	255	286	8	2,2	2,5	0,102	0,111
	228	230	289	161	30	4	27,3	-	245	195	275	303	22	3,2	3	0,107	0,104
170	225	220	266	112	30,5	2,1	16,1	-	235	199	255	279	9	1,9	2	0,113	0,107
	228	220	289	141	30,5	3	19	-	227	202	290	306	9	9,1	2,5	0,096	0,113
	224	240	296	141	31	4	22,5	-	250	202	275	323	21	1,6	3	0,108	0,108
180	235	240	285	120	31,5	2,1	15,2	-	250	210	275	299	9	2,9	2	0,123	0,095
	245	250	305	150	32	3	27,3	-	260	212	307	326	9	-	2,5	0,108	0,104

¹⁾ Permissible axial displacement from normal position of one bearing ring in relation to the other (→ page 40)

²⁾ To clear the cage for caged bearings or to clear the snap ring for full complement bearings

³⁾ To clear the cage for caged bearings

⁴⁾ Minimum width of free space for bearings with the cage in normal position (→ page 18)

CARB toroidal roller bearings on an adapter sleeve

d_1 200 – 430 mm

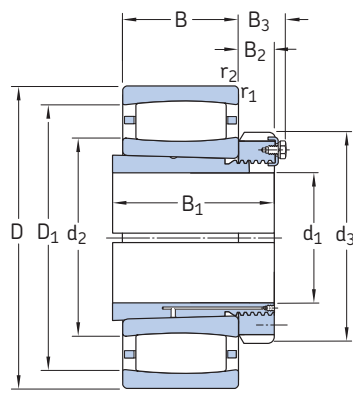

Bearing on an OH .. H(TL)-design adapter sleeve

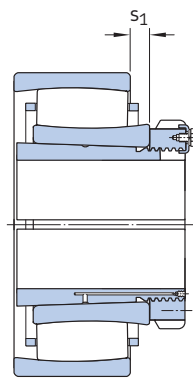

Bearing on an OH .. HE-design adapter sleeve

Principal dimensions			Basic load ratings		Fatigue load limit	Speed ratings		Mass Bearing + sleeve	Designations Bearing	Adapter sleeve
d_1	D	B	dynamic	static		Reference speed	Limiting speed			
mm			C	C_0	P_u	r/min	kg	–		
200	340	90	1 320	2 040	176	1 600	2 200	37,0	C 3044 K	OH 3044 H
	370	120	1 900	2 900	245	1 400	1 900	64,0	C 3144 K	OH 3144 HTL
	400	108	2 000	2 500	216	1 500	2 000	69,0	C 2244 K	OH 3144 H
220	360	92	1 340	2 160	180	1 400	2 000	42,5	C 3048 K	OH 3048 H
	400	128	2 320	3 450	285	1 300	1 700	77,0	C 3148 K	OH 3148 HTL
240	400	104	1 760	2 850	232	1 300	1 800	59,0	C 3052 K	OH 3052 H
	440	144	2 650	4 050	325	1 100	1 500	105	C 3152 K	OH 3152 HTL
260	420	106	1 860	3 100	250	1 200	1 600	65,0	C 3056 K	OH 3056 H
	460	146	2 850	4 500	355	1 100	1 400	115	C 3156 K	OH 3156 HTL
280	460	118	2 160	3 750	290	1 100	1 500	91,0	C 3060 KM	OH 3060 H
	500	160	3 250	5 200	400	1 000	1 300	150	C 3160 K	OH 3160 H
300	480	121	2 280	4 000	310	1 000	1 400	95,0	C 3064 KM	OH 3064 H
	540	176	4 150	6 300	480	950	1 300	190	C 3164 KM	OH 3164 H
320	520	133	2 900	5 000	375	950	1 300	125	▶ C 3068 KM	OH 3068 H
	580	190	4 900	7 500	560	850	1 200	235	C 3168 KM	OH 3168 H
340	480	90	1 760	3 250	250	1 000	1 400	73,0	C 3972 KM	OH 3972 HE
	540	134	2 900	5 000	375	900	1 200	135	▶ C 3072 KM	OH 3072 H
	600	192	5 000	8 000	585	800	1 100	250	C 3172 KM	OH 3172 H
360	520	106	2 120	4 000	300	950	1 300	95	▶ C 3976 KM	OH 3976 H
	560	135	3 000	5 200	390	900	1 200	145	▶ C 3076 KM	OH 3076 H
	620	194	4 400	7 200	520	750	1 000	298	C 3176 KMB	OH 3176 HE
380	540	106	2 120	4 000	290	900	1 300	102	▶ C 3980 KM	OH 3980 HE
	600	148	3 650	6 200	450	800	1 100	175	▶ C 3080 KM	OH 3080 H
	650	200	4 800	8 300	585	700	950	325	C 3180 KM	OH 3180 H
400	560	106	2 160	4 250	310	850	1 200	105	C 3984 KM	OH 3984 HE
	620	150	3 800	6 400	465	800	1 100	180	C 3084 KM	OH 3084 H
	700	224	6 000	10 400	710	670	900	395	C 3184 KM	OH 3184 H
410	600	118	2 600	5 300	375	800	1 100	155	▶ C 3988 KM	OH 3988 HE
	650	157	3 750	6 400	465	750	1 000	250	C 3088 KMB	OH 3088 HE
	720	226	6 700	11 400	780	630	850	470	C 3188 KMB	OH 3188 HE
430	620	118	2 700	5 300	375	800	1 100	160	▶ C 3992 KMB	OH 3992 HE
	680	163	4 000	7 500	510	700	950	270	C 3092 KM	OH 3092 H
	760	240	6 800	12 000	800	600	800	540	C 3192 KM	OH 3192 H

▶ Please check availability of the bearing before incorporating it in a bearing arrangement design

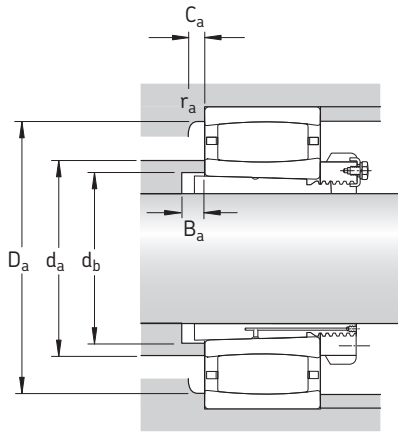

Dimensions										Abutment and fillet dimensions						Calculation factors	
d_1	d_2	d_3	D_1	B_1	B_2	B_3	$r_{1,2}$	$s_{1,2}^{1)}$	$d_a^{2)}$	d_b	$D_a^{2)}$	D_a	B_a	$C_a^{3)}$	r_a	k_1	k_2
mm										mm						-	
200	257	260	310	126	30	41	3	17,2	270	231	295	327	9	3,1	2,5	0,114	0,104
	268	260	333	161	30	41	4	22,3	290	233	315	353	9	3,5	3	0,114	0,097
	259	280	350	161	35	-	4	20,5	295	233	320	383	21	1,7	3	0,113	0,101
220	276	290	329	133	34	46	3	19,2	290	251	315	347	11	1,3	2,5	0,113	0,106
	281	290	357	172	34	46	4	20,4	305	254	335	383	11	3,7	3	0,116	0,095
240	305	310	367	145	34	46	4	19,3	325	272	350	385	11	3,4	3	0,122	0,096
	314	310	394	190	34	46	4	26,4	340	276	375	423	11	4,1	3	0,115	0,096
260	328	330	389	152	38	50	4	21,3	350	292	375	405	12	1,8	3	0,121	0,098
	336	330	416	195	38	50	5	28,4	360	296	395	440	12	4,1	4	0,115	0,097
280	352	360	417	168	42	54	4	20	375	313	405	445	12	1,7	3	0,123	0,095
	362	380	448	208	40	53	5	30,5	390	318	425	480	12	4,9	4	0,106	0,106
300	376	380	440	171	42	55	4	23,3	395	334	430	465	13	1,8	3	0,121	0,098
	372	400	476	226	42	56	5	26,7	410	338	455	520	13	3,9	4	0,114	0,096
320	402	400	482	187	45	58	5	25,4	430	355	465	502	14	1,9	4	0,12	0,099
	405	440	517	254	55	72	5	25,9	445	360	490	560	14	4,2	4	0,118	0,093
340	394	420	450	144	45	58	3	17,2	405	372	440	467	14	1,6	2,5	0,127	0,104
	417	420	497	188	45	58	5	26,4	445	375	480	522	14	2	4	0,12	0,099
	423	460	537	259	58	75	5	27,9	460	380	510	580	14	3,9	4	0,117	0,094
360	428	450	489	164	48	62	4	21	450	393	475	505	15	1,8	3	0,129	0,098
	431	450	511	193	48	62	5	27	460	396	495	542	15	2	4	0,12	0,1
	446	490	551	264	60	77	5	25,4	445	401	526	600	15	7,3	4	-	0,106
380	439	470	501	168	52	66	4	21	461	413	487	525	15	1,8	3	0,13	0,098
	458	470	553	210	52	66	5	30,6	480	417	525	582	15	2,1	4	0,121	0,099
	488	520	589	272	62	82	6	50,7	526	421	564	624	15	2,5	5	0,106	0,109
400	462	490	522	168	52	66	4	21,3	480	433	515	545	15	1,8	3	0,132	0,098
	475	490	570	212	52	66	5	32,6	510	437	550	602	16	2,2	4	0,12	0,1
	508	540	618	304	70	90	6	34,8	540	443	595	674	16	3,8	5	0,113	0,098
410	494	520	560	189	60	77	4	20	517	454	546	585	17	1,9	3	0,133	0,095
	491	520	587	228	60	77	6	19,7	489	458	565	627	17	1,7	5	-	0,105
	522	560	647	307	70	90	6	16	521	463	613	694	17	7,5	5	-	0,099
430	508	540	577	189	60	77	4	11	505	474	580	605	17	10,4	3	-	0,12
	539	540	624	234	60	77	6	33,5	565	478	605	657	17	2,3	5	0,114	0,108
	559	580	679	326	75	95	7,5	51	570	484	655	728	17	4,2	6	0,108	0,105

1) Permissible axial displacement from normal position of one bearing ring in relation to the other (→ page 40)

2) To clear the cage

3) Minimum width of free space for bearings with the cage in normal position (→ page 18)

CARB toroidal roller bearings on an adapter sleeve

d_1 450 – 850 mm

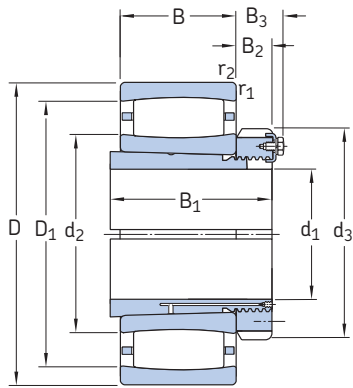

Bearing on an OH .. H-design adapter sleeve

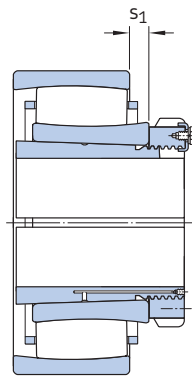

Bearing on an OH .. HE-design adapter sleeve

Principal dimensions			Basic load ratings		Fatigue load limit	Speed ratings		Mass Bearing + sleeve	Designations Bearing	Adapter sleeve
d_1	D	B	dynamic	static		Reference speed	Limiting speed			
mm			C	C_0	P_u	r/min	kg	–		
450	650	128	3 100	6 100	430	750	1 000	185	C 3996 KM	OH 3996 H
	700	165	4 050	7 800	530	670	900	275	C 3096 KM	OH 3096 H
	790	248	6 950	12 500	830	560	750	620	▶ C 3196 KMB	OH 3196 HE
470	670	128	3 150	6 300	440	700	950	195	C 39/500 KM	OH 39/500 HE
	720	167	4 250	8 300	560	630	900	305	C 30/500 KM	OH 30/500 H
	830	264	7 500	12 700	850	530	750	690	C 31/500 KM	OH 31/500 H
500	710	136	3 550	7 100	490	670	900	230	C 39/530 KM	OH 39/530 HE
	780	185	5 100	9 500	640	600	800	390	C 30/530 KM	OH 30/530 H
	870	272	8 800	15 600	1 000	500	670	770	C 31/530 KM	OH 31/530 H
530	750	140	3 600	7 350	490	600	850	260	C 39/560 KM	OH 39/560 HE
	820	195	5 600	11 000	720	530	750	440	C 30/560 KM	OH 30/560 H
	920	280	9 500	17 000	1 100	480	670	930	▶ C 31/560 KMB	OH 31/560 HE
560	800	150	4 000	8 800	570	560	750	325	C 39/600 KM	OH 39/600 HE
	870	200	6 300	12 200	780	500	700	520	C 30/600 KM	OH 30/600 H
	980	300	10 200	18 000	1 140	430	600	1 135	C 31/600 KMB	OH 31/600 HE
600	850	165	4 650	10 000	640	530	700	420	C 39/630 KM	OH 39/630 HE
	920	212	6 800	12 900	830	480	670	635	C 30/630 KM	OH 30/630 H
	1 030	315	11 800	20 800	1 290	400	560	1 310	C 31/630 KMB	OH 31/630 HE
630	900	170	5 100	11 600	720	480	630	490	C 39/670 KMB	OH 39/670 HE
	980	230	8 150	16 300	1 000	430	600	750	C 30/670 KM	OH 30/670 H
	1 090	336	12 000	22 000	1 320	380	530	1 550	▶ C 31/670 KMB	OH 31/670 HE
670	950	180	6 000	12 500	780	450	630	520	C 39/710 KM	OH 39/710 HE
	1 030	236	8 800	17 300	1 060	400	560	865	C 30/710 KM	OH 30/710 H
	1 150	345	12 700	24 000	1 430	360	480	1 800	▶ C 31/710 KMB	OH 31/710 HE
710	1 000	185	6 100	13 400	815	430	560	590	C 39/750 KM	OH 39/750 HE
	1 090	250	9 500	19 300	1 160	380	530	1 060	C 30/750 KMB	OH 30/750 HE
	1 220	365	13 700	30 500	1 800	320	450	2 200	C 31/750 KMB	OH 31/750 HE
750	1 060	195	5 850	15 300	915	380	530	750	▶ C 39/800 KMB	OH 39/800 HE
	1 150	258	9 150	18 600	1 120	360	480	1 150	C 30/800 KMB	OH 30/800 HE
	1 280	375	15 600	30 500	1 760	300	400	2 400	▶ C 31/800 KMB	OH 31/800 HE
800	1 120	200	7 350	16 300	965	360	480	785	C 39/850 KM	OH 39/850 HE
	1 220	272	11 600	24 500	1 430	320	450	1 415	C 30/850 KMB	OH 30/850 HE
	1 360	400	16 000	32 000	1 830	280	380	2 260	▶ C 31/850 KMB	OH 31/850 HE
850	1 180	206	8 150	18 000	1 060	340	450	900	▶ C 39/900 KMB	OH 39/900 HE
	1 280	280	12 700	26 500	1 530	300	400	1 540	C 30/900 KMB	OH 30/900 HE

▶ Please check availability of the bearing before incorporating it in a bearing arrangement design

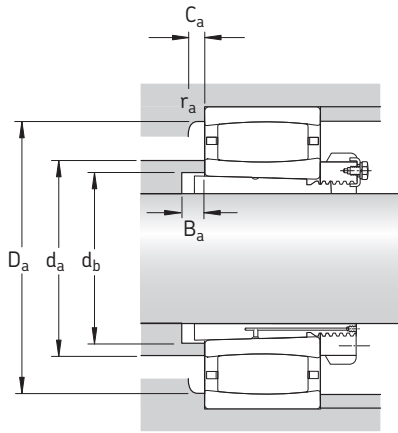

Dimensions **Abutment and fillet dimensions** **Calculation factors**

d ₁	d ₂	d ₃	D ₁	B ₁	B ₂	B ₃	r _{1,2}	s ₁ ¹⁾	d _a ²⁾	d _b	D _a ²⁾	D _a	B _a	C _a ³⁾	r _a	k ₁	k ₂
mm									mm							-	
450	529	560	604	200	60	77	5	20,4	550	496	590	632	18	2	4	0,133	0,095
	555	560	640	237	60	77	6	35,5	580	499	625	677	18	2,3	5	0,113	0,11
	583	620	700	335	75	95	7,5	24	580	505	705	758	18	20,6	6	-	0,104
470	556	580	631	208	68	85	5	20,4	580	516	615	652	18	2	4	0,135	0,095
	572	580	656	247	68	85	6	37,5	600	519	640	697	18	2,3	5	0,113	0,111
	605	630	738	356	80	100	7,5	75,3	655	527	705	798	18	-	6	0,099	0,116
500	578	630	657	216	68	90	5	28,4	600	547	640	692	20	2,2	4	0,129	0,101
	601	630	704	265	68	90	6	35,7	635	551	685	757	20	2,5	5	0,12	0,101
	635	670	781	364	80	105	7,5	44,4	680	558	745	838	20	4,8	6	0,115	0,097
530	622	650	701	227	75	97	5	32,4	645	577	685	732	20	2,3	4	0,128	0,104
	660	650	761	282	75	97	6	45,7	695	582	740	797	20	2,7	5	0,116	0,106
	664	710	808	377	85	110	7,5	28	660	589	810	888	20	23,8	6	-	0,111
560	666	700	744	239	75	97	5	32,4	685	619	725	782	22	2,4	4	0,131	0,1
	692	700	805	289	75	97	6	35,9	725	623	775	847	22	2,7	5	0,125	0,098
	705	750	871	399	85	110	7,5	26,1	704	632	827	948	22	5,1	6	-	0,107
600	700	730	784	254	75	97	6	35,5	720	650	770	827	22	2,4	5	0,121	0,11
	717	730	840	301	75	97	7,5	48,1	755	654	810	892	22	2,9	6	0,118	0,104
	741	800	916	424	95	120	7,5	23,8	740	663	868	998	22	5,7	6	-	0,102
630	761	780	848	264	80	102	6	24,9	760	691	833	877	22	4,2	5	-	0,113
	775	780	904	324	80	102	7,5	41,1	820	696	875	952	22	2,9	6	0,121	0,101
	797	850	963	456	106	131	7,5	33	795	705	965	1058	22	28	6	-	0,104
670	773	830	877	286	90	112	6	30,7	795	732	850	927	26	2,7	5	0,131	0,098
	807	830	945	342	90	112	7,5	47,3	850	736	910	1002	26	3,2	6	0,119	0,104
	848	900	1012	467	106	135	9,5	34	845	745	1015	1110	26	28,6	8	-	0,102
710	830	870	933	291	90	112	6	35,7	855	772	910	977	26	2,7	5	0,131	0,101
	854	870	993	356	90	112	7,5	28,6	852	778	961	1062	26	7,4	6	-	0,11
	884	950	1077	493	112	141	9,5	33	883	787	1025	1180	26	9,3	8	-	0,094
750	885	920	990	303	90	112	6	28,1	883	825	971	1037	28	5,3	5	-	0,106
	913	920	1047	366	90	112	7,5	25	910	829	1050	1122	28	22,3	6	-	0,111
	947	1000	1133	505	112	141	9,5	37	945	838	1135	1240	28	32,1	8	-	0,115
800	940	980	1053	308	90	115	6	35,9	960	876	1025	1097	28	2,9	5	0,135	0,098
	964	980	1113	380	90	115	7,5	24	963	880	1077	1192	28	7,7	6	-	0,097
	1020	1060	1200	536	118	147	12	40	1015	890	1205	1312	28	33,5	10	-	0,11
850	989	1030	1113	326	100	125	6	20	985	924	1115	1157	30	18,4	5	-	0,132
	1004	1030	1173	400	100	125	7,5	25,5	1002	931	1124	1252	30	3,3	6	-	0,1

¹⁾ Permissible axial displacement from normal position of one bearing ring in relation to the other (→ page 40)

²⁾ To clear the cage

³⁾ Minimum width of free space for bearings with the cage in normal position (→ page 18)

CARB toroidal roller bearings on an adapter sleeve

d_1 900 – 1 000 mm

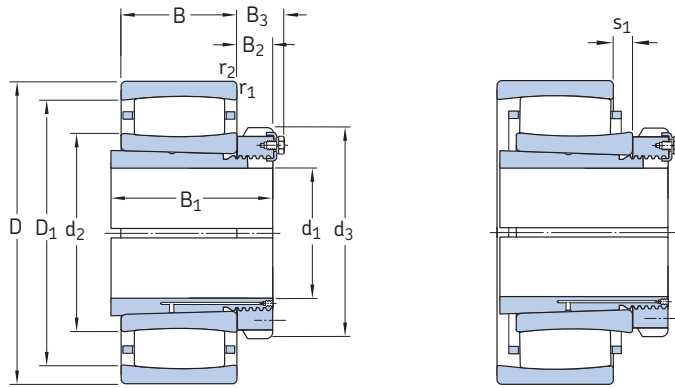

Principal dimensions			Basic load ratings		Fatigue load limit	Speed ratings		Mass Bearing + sleeve	Designations Bearing	Adapter sleeve
d_1	D	B	dynamic C	static C_0		Reference speed	Limiting speed			
mm			kN		kN	r/min		kg	–	
900	1 250	224	9 300	22 000	1 250	300	430	1 120	▶ C 39/950 KMB ▶ C 30/950 KMB	OH 39/950 HE OH 30/950 HE
	1 360	300	12 900	27 500	1 560	280	380	1 800		
950	1 420	308	13 400	29 000	1 630	260	340	2 000	▶ C 30/1000 KMB ▶ C 31/1000 KMB	OH 30/1000 HE OH 31/1000 HE
	1 580	462	22 800	45 500	2 500	220	300	4 300		
1 000	1 400	250	11 000	26 000	1 430	260	360	1 610	▶ C 39/1060 KMB	OH 39/1060 HE

▶ Please check availability of the bearing before incorporating it in a bearing arrangement design

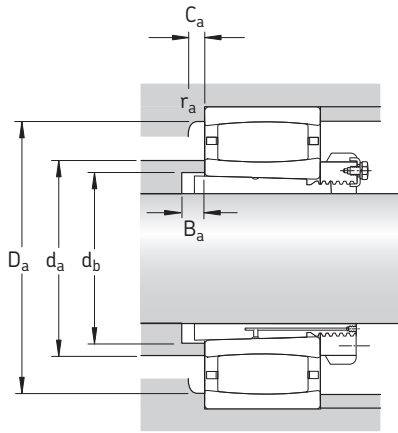

Dimensions									Abutment and fillet dimensions							Calculation factors	
d_1	d_2 ≈	d_3	D_1 ≈	B_1	B_2	B_3	$r_{1,2}$ min	$s_1^{1)}$ ≈	$d_a^{2)}$ max	d_b min	$D_a^{2)}$ min	D_a max	B_a min	$C_a^{3)}$ min	r_a max	k_1	k_2
mm									mm							-	
900	1 042	1 080	1 167	344	100	125	7,5	14,5	1 040	976	1 139	1 222	30	6,6	6	-	0,098
	1 080	1 080	1 240	420	100	125	7,5	30	1 075	983	1 245	1 332	30	26,2	6	-	0,116
950	1 136	1 140	1 294	430	100	125	7,5	30	1 135	1 034	1 295	1 392	33	26,7	6	-	0,114
	1 179	1 240	1 401	609	125	154	12	46	1 175	1 047	1 405	1 532	33	38,6	10	-	0,105
1 000	1 175	1 200	1 323	372	100	125	7,5	25	1 170	1 090	1 325	1 392	33	23,4	6	-	0,11

¹⁾ Permissible axial displacement from normal position of one bearing ring in relation to the other (→ page 40)

²⁾ To clear the cage

³⁾ Minimum width of free space for bearings with the cage in normal position (→ page 18)

CARB toroidal roller bearings on a withdrawal sleeve

d_1 35 – 95 mm

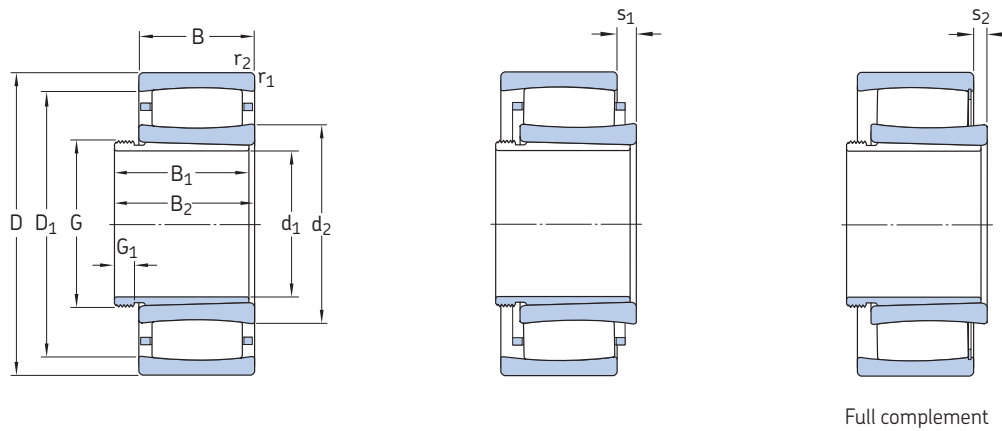

Principal dimensions			Basic load ratings		Fatigue load limit	Speed ratings		Mass Bearing + sleeve	Designations Bearing	Withdrawal sleeve
d_1	D	B	dynamic	static		Reference speed	Limiting speed			
mm			C	C_0	P_u	r/min	kg	–		
35	80	23	90	86,5	10,2	8 000	11 000	0,59	C 2208 KTN9	AH 308
	80	23	102	104	12	–	4 500	0,62	C 2208 KV	AH 308
40	85	23	93	93	10,8	8 000	11 000	0,67	C 2209 KTN9	AH 309
	85	23	106	110	12,9	–	4 300	0,70	C 2209 KV	AH 309
45	90	23	98	100	11,8	7 000	9 500	0,72	C 2210 KTN9	AHX 310
	90	23	114	122	14,3	–	3 800	0,75	C 2210 KV	AHX 310
50	100	25	116	114	13,4	6 700	9 000	0,95	C 2211 KTN9	AHX 311
	100	25	132	134	16	–	3 400	0,97	C 2211 KV	AHX 311
55	110	28	143	156	18,3	5 600	7 500	1,30	C 2212 KTN9	AHX 312
	110	28	166	190	22,4	–	2 800	1,35	C 2212 KV	AHX 312
60	120	31	180	180	21,2	5 300	7 500	1,60	C 2213 KTN9	AH 313 G
	120	31	204	216	25,5	–	2 400	1,70	C 2213 KV	AH 313 G
65	125	31	186	196	23,2	5 000	7 000	1,70	C 2214 KTN9	AH 314 G
	125	31	212	228	27	–	2 400	1,75	C 2214 KV	AH 314 G
	150	51	405	430	49	3 800	5 000	4,65	C 2314 K	AHX 2314 G
70	130	31	196	208	25,5	4 800	6 700	1,90	C 2215 K	AH 315 G
	130	31	220	240	29	–	2 200	1,95	C 2215 KV	AH 315 G
	160	55	425	465	52	3 600	4 800	5,65	C 2315 K	AHX 2315 G
75	140	33	220	250	28,5	4 500	6 000	2,35	C 2216 K	AH 316
	140	33	255	305	34,5	–	2 000	2,45	C 2216 KV	AH 316
	170	58	510	550	61	3 400	4 500	6,75	C 2316 K	AHX 2316
80	150	36	275	320	36,5	4 300	5 600	3,00	C 2217 K	AHX 317
	150	36	315	390	44	–	1 800	3,20	► C 2217 KV	AHX 317
	180	60	540	600	65,5	3 200	4 300	7,90	C 2317 K	AHX 2317
85	160	40	325	380	42,5	3 800	5 300	3,75	C 2218 K	AHX 318
	160	40	365	440	49	–	1 500	3,85	► C 2218 KV	AHX 318
	190	64	610	695	73,5	2 800	4 000	9,00	C 2318 K	AHX 2318
90	170	43	360	400	44	3 800	5 000	4,50	► C 2219 K	AHX 319
	200	67	610	695	73,5	2 800	4 000	11,0	C 2319 K	AHX 2319
95	165	52	475	655	71	–	1 300	5,00	C 3120 KV	AHX 3120
	180	46	415	465	47,5	3 600	4 800	5,30	C 2220 K	AHX 320
	215	73	800	880	91,5	2 600	3 600	13,5	C 2320 K	AHX 2320

► Please check availability of the bearing before incorporating it in a bearing arrangement design

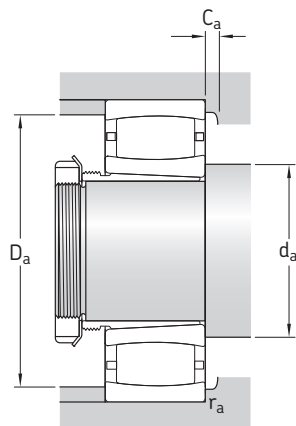

Dimensions						Abutment and fillet dimensions						Calculation factors					
d_1	d_2	D_1	B_1	$B_2^{1)}$	G	G_1	$r_{1,2}$ min	$s_1^{2)}$	$s_2^{2)}$	d_a min	$d_a^{3)}$ max	$D_a^{4)}$ min	D_a max	$C_a^{5)}$ min	r_a max	k_1	k_2
mm										mm				-			
35	52,4	69,9	29	32	M 45×1,5	6	1,1	7,1	-	47	52	68	73	0,3	1	0,093	0,128
	52,4	69,9	29	32	M 45×1,5	6	1,1	7,1	4,1	47	66	-	73	-	1	0,093	0,128
40	55,6	73,1	31	34	M 50×1,5	6	1,1	7,1	-	52	55	71	78	0,3	1	0,095	0,128
	55,6	73,1	31	34	M 50×1,5	6	1,1	7,1	4,1	52	69	-	78	-	1	0,095	0,128
45	61,9	79,4	35	38	M 55×2	7	1,1	7,1	-	57	61	77	83	0,8	1	0,097	0,128
	61,9	79,4	35	38	M 55×2	7	1,1	7,1	3,9	57	73	-	83	-	1	0,097	0,128
50	65,8	86,7	37	40	M 60×2	7	1,5	8,6	-	64	65	84	91	0,3	1,5	0,094	0,133
	65,8	86,7	37	40	M 60×2	7	1,5	8,6	5,4	64	80	-	91	-	1,5	0,094	0,133
55	77,1	97,9	40	43	M 65×2	8	1,5	8,5	-	69	77	95	101	0,3	1,5	0,1	0,123
	77,1	97,9	40	43	M 65×2	8	1,5	8,5	5,3	69	91	-	101	-	1,5	0,1	0,123
60	79	106	42	45	M 70×2	8	1,5	9,6	-	74	79	102	111	0,2	1,5	0,097	0,127
	79	106	42	45	M 70×2	8	1,5	9,6	5,3	74	97	-	111	-	1,5	0,097	0,127
65	83,7	111	43	47	M 75×2	8	1,5	9,6	-	79	83	107	116	0,4	1,5	0,098	0,127
	83,7	111	43	47	M 75×2	8	1,5	9,6	5,3	79	102	-	116	-	1,5	0,098	0,127
	91,4	130	64	68	M 75×2	12	2,1	9,1	-	82	105	120	138	2,2	2	0,11	0,099
70	88,5	115	45	49	M 80×2	8	1,5	9,6	-	84	98	110	121	1,2	1,5	0,099	0,127
	88,5	115	45	49	M 80×2	8	1,5	9,6	5,3	84	105	-	121	-	1,5	0,099	0,127
	98,5	135	68	72	M 80×2	12	2,1	13,1	-	87	110	130	148	2,2	2	0,103	0,107
75	98,1	125	48	52	M 90×2	8	2	9,1	-	91	105	120	129	1,2	2	0,104	0,121
	98,1	125	48	52	M 90×2	8	2	9,1	4,8	91	115	-	129	-	2	0,104	0,121
	102	145	71	75	M 90×2	12	2,1	10,1	-	92	115	135	158	2,4	2	0,107	0,101
80	104	133	52	56	M 95×2	9	2	7,1	-	96	110	125	139	1,3	2	0,114	0,105
	104	133	52	56	M 95×2	9	2	7,1	1,7	96	115	-	139	-	2	0,114	0,105
	110	153	74	78	M 95×2	13	3	12,1	-	99	125	145	166	2,4	2,5	0,105	0,105
85	112	144	53	57	M 100×2	9	2	9,5	-	101	120	130	149	1,4	2	0,104	0,117
	112	144	53	57	M 100×2	9	2	9,5	5,4	101	125	-	149	-	2	0,104	0,117
	119	166	79	83	M 100×2	14	3	9,6	-	104	135	155	176	2	2,5	0,108	0,101
90	113	149	57	61	M 105×2	10	2,1	10,5	-	107	112	149	158	4,2	2	0,114	0,104
	120	166	85	89	M 105×2	16	3	12,6	-	109	135	155	186	2,1	2,5	0,103	0,106
95	119	150	64	68	M 110×2	11	2	10	4,7	111	130	-	154	-	2	0,1	0,112
	118	157	59	63	M 110×2	10	2,1	10,1	-	112	130	150	168	0,9	2	0,108	0,11
	126	185	90	94	M 110×2	16	3	11,2	-	114	150	170	201	3,2	2,5	0,113	0,096

1) Width before the sleeve is driven into bearing bore

2) Permissible axial displacement from normal position of one bearing ring in relation to the other (→ page 40)

3) To clear the cage for caged bearings or to clear the snap ring for full complement bearings

4) To clear the cage for caged bearings

5) Minimum width of free space for bearings with the cage in normal position (→ page 18)

CARB toroidal roller bearings on a withdrawal sleeve

d₁ 105 – 160 mm

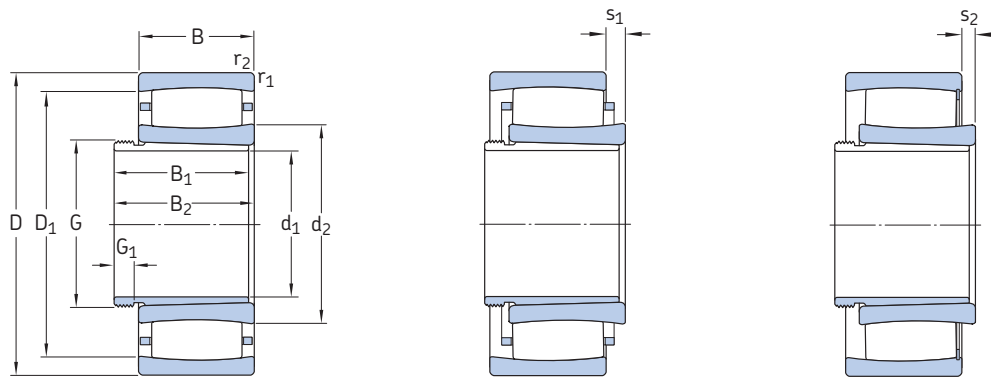

Full complement

Principal dimensions			Basic load ratings		Fatigue load limit	Speed ratings		Mass	Designations	Withdrawal sleeve
d ₁	D	B	C	C ₀	P _u	Reference speed	Limiting speed	Bearing + sleeve	Bearing	
mm			kN		kN	r/min		kg	–	
105	170	45	355	480	51	3 200	4 500	4,25	▶ C 3022 K	AHX 3122
	180	69	670	1 000	102	–	900	7,75	C 4122 K30V	AH 24122
	200	53	530	620	64	3 200	4 300	7,65	C 2222 K	AHX 3122
115	180	46	375	530	55	3 000	4 000	4,60	▶ C 3024 K	AHX 3024
	180	46	430	640	67	–	1 400	4,75	C 3024 KV	AH 3024
	180	60	530	880	90	–	1 100	6,20	C 4024 K30V	AH 24024
	180	60	430	640	65,5	–	1 400	5,65	C 4024 K30V/VE240	AH 24024
	200	80	780	1 120	114	–	750	11,5	▶ C 4124 K30V	AH 24124
	215	58	610	710	72	3 000	4 000	9,50	▶ C 2224 K	AHX 3124
	215	76	750	980	98	2 400	3 200	13,0	C 3224 K	AHX 3224 G
125	200	52	390	585	58,5	2 800	3 800	6,80	▶ C 3026 K	AHX 3026
	200	69	620	930	91,5	1 900	2 800	8,70	C 4026 K30	AH 24026
	200	69	720	1 120	112	–	850	8,90	C 4026 K30V	AH 24026
	210	80	750	1 100	108	–	670	11,5	C 4126 K30V/VE240	AH 24126
	230	64	735	930	93	2 800	3 800	12,0	C 2226 K	AHX 3126
135	210	53	490	735	72	2 600	3 400	7,30	▶ C 3028 K	AHX 3028
	210	69	750	1 220	118	–	800	9,50	C 4028 K30V	AH 24028
	225	85	1 000	1 600	153	–	630	15,5	C 4128 K30V	AH 24128
	250	68	830	1 060	102	2 400	3 400	15,5	C 2228 K	AHX 3128
145	225	56	540	850	83	2 400	3 200	9,40	▶ C 3030 KMB	AHX 3030
	225	56	585	960	93	–	1 000	8,9	C 3030 KV	AH 3030
	225	75	780	1 320	125	–	750	11,5	C 4030 K30V	AH 24030
	250	80	880	1 290	122	2 000	2 800	16,5	C 3130 K	AHX 3130 G
	250	100	1 220	1 860	173	–	450	22,0	▶ C 4130 K30V	AH 24130
	270	73	980	1 220	116	2 400	3 200	19,0	C 2230 K	AHX 3130 G
150	240	60	600	980	93	2 200	3 000	11,5	▶ C 3032 K	AH 3032
	240	80	795	1 160	110	1 600	2 400	14,7	C 4032 K30	AH 24032
	240	80	915	1 460	140	–	600	15,0	C 4032 K30V	AH 24032
	270	86	1 000	1 400	129	1 900	2 600	24,0	C 3132 KMB	AH 3132 G
	270	109	1 460	2 160	200	–	300	29,0	▶ C 4132 K30V	AH 24132
	290	104	1 370	1 830	170	1 700	2 400	31,0	C 3232 K	AH 3232 G
	160	260	67	750	1 160	108	2 000	2 800	15,0	▶ C 3034 K
260		90	1 140	1 860	170	–	480	20,0	C 4034 K30V	AH 24034
280		88	1 040	1 460	137	1 900	2 600	24,0	▶ C 3134 K	AH 3134 G
280		109	1 530	2 280	208	–	280	30,0	▶ C 4134 K30V	AH 24134
310		86	1 270	1 630	150	2 000	2 600	31,0	C 2234 K	AH 3134 G

▶ Please check availability of the bearing before incorporating it in a bearing arrangement design

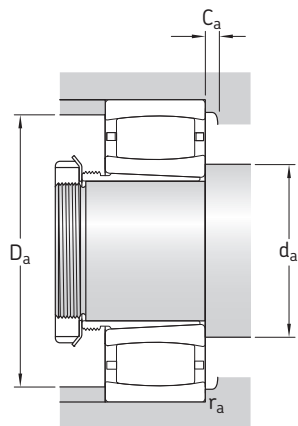

Dimensions							Abutment and fillet dimensions							Calculation factors			
d_1	d_2	D_1	B_1	$B_2^{1)}$	G	G_1	$r_{1,2}$ min	$s_1^{2)}$	$s_2^{2)}$	d_a min	$d_a^{3)}$ max	$D_a^{4)}$ min	D_a max	$C_a^{5)}$ min	r_a max	k_1	k_2
mm										mm				-			
105	128	156	68	72	M 120x2	11	2	9,5	-	119	127	157	161	4	2	0,107	0,11
	132	163	82	91	M 115x2	13	2	11,4	4,6	120	145	-	170	-	2	0,111	0,097
	132	176	68	72	M 120x2	11	2,1	11,1	-	122	150	165	188	1,9	2	0,113	0,103
115	138	166	60	64	M 130x2	13	2	10,6	-	129	145	160	171	0,9	2	0,111	0,109
	138	166	60	64	M 130x2	13	2	10,6	3,8	129	150	-	171	-	2	0,111	0,109
	140	164	73	82	M 125x2	13	2	12	5,2	129	150	-	171	-	2	0,109	0,103
	139	164	73	82	M 125x2	13	2	-	17,8	130	152	142	170	-	2	0,085	0,142
	140	176	93	102	M 130x2	13	2	18	11,2	131	140	-	189	-	2	0,103	0,103
	144	191	75	79	M 130x2	12	2,1	13	-	132	143	192	203	5,4	2	0,113	0,103
	149	190	90	94	M 130x2	13	2,1	17,1	-	132	160	180	203	2,4	2	0,103	0,108
125	154	180	67	71	M 140x2	14	2	16,5	-	139	152	182	191	4,4	2	0,123	0,1
	149	181	83	93	M 140x2	14	2	11,4	-	139	155	175	191	1,9	2	0,113	0,097
	149	181	83	93	M 135x2	14	2	11,4	4,6	139	165	-	191	-	2	0,113	0,097
	153	190	94	104	M 140x2	14	2	9,7	9,7	141	170	-	199	-	2	0,09	0,126
	152	199	78	82	M 140x2	12	3	9,6	-	144	170	185	216	1,1	2,5	0,113	0,101
135	163	194	68	73	M 150x2	14	2	11	-	149	161	195	201	4,7	2	0,102	0,116
	161	193	83	93	M 145x2	14	2	11,4	5,9	149	175	-	201	-	2	0,115	0,097
	167	203	99	109	M 150x2	14	2,1	12	5,2	151	185	-	214	-	2	0,111	0,097
	173	223	83	88	M 150x2	14	3	13,7	-	154	190	210	236	2,3	2,5	0,109	0,108
145	173	204	72	77	M 160x3	15	2,1	8,7	-	161	172	200	214	1,3	2	-	0,108
	174	204	72	77	M 160x3	15	2,1	14,1	7,3	161	190	177	214	-	2	0,113	0,108
	173	204	90	101	M 155x3	15	2,1	17,4	10,6	161	185	-	214	-	2	0,107	0,106
	182	226	96	101	M 160x3	15	2,1	13,9	-	162	195	215	238	2,3	2	0,12	0,092
	179	222	115	126	M 160x3	15	2,1	20	10,1	162	175	-	228	-	2	0,103	0,103
	177	236	96	101	M 160x3	15	3	11,2	-	164	200	215	256	2,5	2,5	0,119	0,096
150	187	218	77	82	M 170x3	16	2,1	15	-	171	186	220	229	5,1	2	0,115	0,106
	181	217	95	106	M 170x3	15	2,1	18,1	-	171	190	210	229	2,2	2	0,109	0,103
	181	217	95	106	M 170x3	15	2,1	18,1	8,2	171	195	-	229	-	2	0,109	0,103
	190	240	103	108	M 170x3	16	2,1	10,3	-	172	189	229	258	3,8	2	-	0,099
	190	241	124	135	M 170x3	15	2,1	21	11,1	172	190	-	258	-	2	0,101	0,105
	194	256	124	130	M 170x3	20	3	19,3	-	174	215	245	276	2,6	2,5	0,112	0,096
160	200	237	85	90	M 180x3	17	2,1	12,5	-	181	200	238	249	5,8	2	0,105	0,112
	195	235	106	117	M 180x3	16	2,1	17,1	7,2	181	215	-	249	-	2	0,108	0,103
	200	249	104	109	M 180x3	16	2,1	21	-	182	200	250	268	7,6	2	0,101	0,109
	200	251	125	136	M 180x3	16	2,1	21	11,1	182	200	-	268	-	2	0,101	0,106
	209	274	104	109	M 180x3	16	4	16,4	-	187	230	255	293	3	3	0,114	0,1

1) Width before the sleeve is driven into bearing bore

2) Permissible axial displacement from normal position of one bearing ring in relation to the other (→ page 40)

3) To clear the cage for caged bearings or to clear the snap ring for full complement bearings

4) To clear the cage for caged bearings

5) Minimum width of free space for bearings with the cage in normal position (→ page 18)

CARB toroidal roller bearings on a withdrawal sleeve

d_1 170 – 340 mm

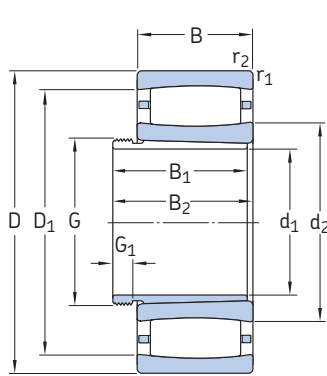

Bearing on an AH-design withdrawal sleeve

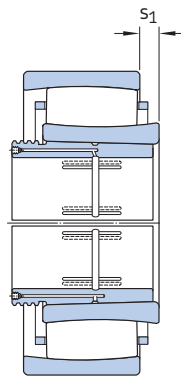

Bearing on an AOH-design withdrawal sleeve

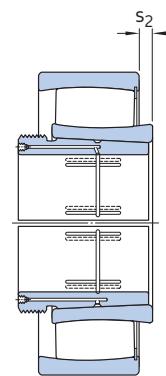

Full complement bearing on an AOH-design withdrawal sleeve

Principal dimensions			Basic load ratings		Fatigue load limit	Speed ratings		Mass	Designations	Withdrawal sleeve
d_1	D	B	C	C_0	P_u	Reference speed	Limiting speed	Bearing + sleeve	Bearing	
mm			kN		kN	r/min		kg	–	
170	280	74	880	1 340	125	1 900	2 600	19,0	C 3036 K	AH 3036
	280	100	1 320	2 120	193	–	430	26,0	C 4036 K30V	AH 24036
	300	96	1 250	1 730	156	1 800	2 400	30,0	C 3136 K	AH 3136 G
	300	118	1 760	2 700	240	–	220	38,0	▶ C 4136 K30V	AH 24136
	320	112	1 530	2 200	196	1 500	2 000	41,5	C 3236 K	AH 3236 G
180	290	75	930	1 460	132	1 800	2 400	20,5	C 3038 K	AH 3038 G
	290	100	1 370	2 320	204	–	380	28,0	▶ C 4038 K30V	AH 24038
	320	104	1 530	2 200	196	1 600	2 200	38,0	▶ C 3138 K	AH 3138 G
	320	128	2 040	3 150	275	–	130	47,5	▶ C 4138 K30V	AH 24138
	340	92	1 370	1 730	156	1 800	2 400	38,0	C 2238 K	AH 2238 G
190	310	82	1 120	1 730	153	1 700	2 400	25,5	C 3040 K	AH 3040 G
	310	109	1 630	2 650	232	–	260	34,5	C 4040 K30V	AH 24040
	340	112	1 600	2 320	204	1 500	2 000	45,5	C 3140 K	AH 3140
	340	140	2 360	3 650	315	–	80	59,0	▶ C 4140 K30V	AH 24140
	200	340	90	1 320	2 040	176	1 600	2 200	36,0	C 3044 K
340		118	1 930	3 250	275	–	200	48,0	▶ C 4044 K30V	AOH 24044
370		120	1 900	2 900	245	1 400	1 900	60,0	C 3144 K	AOH 3144
400		108	2 000	2 500	216	1 500	2 000	65,5	C 2244 K	AOH 2244
220		360	92	1 340	2 160	180	1 400	2 000	39,5	C 3048 K
	400	128	2 320	3 450	285	1 300	1 700	75,0	C 3148 K	AOH 3148
240	400	104	1 760	2 850	232	1 300	1 800	55,5	C 3052 K	AOH 3052
	440	144	2 650	4 050	325	1 100	1 500	102	C 3152 K	AOH 3152 G
260	420	106	1 860	3 100	250	1 200	1 600	61,0	C 3056 K	AOH 3056
	460	146	2 850	4 500	355	1 100	1 400	110	C 3156 K	AOH 3156 G
280	460	118	2 160	3 750	290	1 100	1 500	84,0	C 3060 KM	AOH 3060
	460	160	2 900	4 900	380	850	1 200	110	▶ C 4060 K30M	AOH 24060 G
	500	160	3 250	5 200	400	1 000	1 300	140	C 3160 K	AOH 3160 G
	500	200	4 150	6 700	520	750	1 000	185	C 4160 K30MB	AOH 24160
	300	480	121	2 280	4 000	310	1 000	1 400	93,0	C 3064 KM
540		176	4 150	6 300	480	950	1 300	185	C 3164 KM	AOH 3164 G
320	520	133	2 900	5 000	375	950	1 300	120	▶ C 3068 KM	AOH 3068 G
	580	190	4 900	7 500	560	850	1 200	230	C 3168 KM	AOH 3168 G
340	540	134	2 900	5 000	375	900	1 200	125	▶ C 3072 KM	AOH 3072 G
	600	192	5 000	8 000	585	800	1 100	245	C 3172 KM	AOH 3172 G

▶ Please check availability of the bearing before incorporating it in a bearing arrangement design

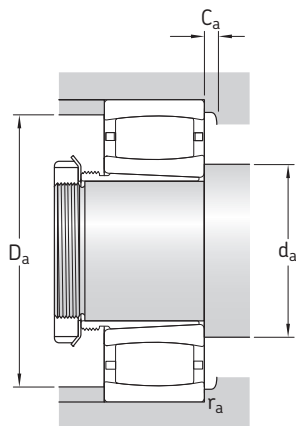

Dimensions							Abutment and fillet dimensions							Calculation factors			
d_1	d_2	D_1	B_1	$B_2^{1)}$	G	G_1	$r_{1,2}$ min	$s_1^{2)}$	$s_2^{2)}$	d_a min	$d_a^{3)}$ max	$D_a^{4)}$ min	D_a max	$C_a^{5)}$ min	r_a max	k_1	k_2
mm										mm				-			
170	209	251	92	98	M 190×3	17	2,1	15,1	-	191	220	240	269	2	2	0,112	0,105
	203	247	116	127	M 190×3	16	2,1	20,1	10,2	191	225	-	269	-	2	0,107	0,103
	210	266	116	122	M 190×3	19	3	23,2	-	194	230	255	286	2,2	2,5	0,102	0,111
	211	265	134	145	M 190×3	16	3	20	10,1	194	210	-	286	-	2,5	0,095	0,11
	228	289	140	146	M 190×3	24	4	27,3	-	197	245	275	303	3,2	3	0,107	0,104
180	225	266	96	102	M 200×3	18	2,1	16,1	-	201	235	255	279	1,9	2	0,113	0,107
	220	263	118	131	M 200×3	18	2,1	20	10,1	201	220	-	279	-	2	0,103	0,106
	228	289	125	131	M 200×3	20	3	19	-	204	227	290	306	9,1	2,5	0,096	0,113
	222	284	146	159	M 200×3	18	3	20	10,1	204	220	-	306	-	2,5	0,094	0,111
	224	296	112	117	M 200×3	18	4	22,5	-	207	250	275	323	1,6	3	0,108	0,108
190	235	285	102	108	Tr 210×4	19	2,1	15,2	-	211	250	275	299	2,9	2	0,123	0,095
	229	280	127	140	Tr 210×4	18	2,1	21	11,1	211	225	-	299	-	2	0,11	0,101
	245	305	134	140	Tr 220×4	21	3	27,3	-	214	260	307	326	-	2,5	0,108	0,104
	237	302	158	171	Tr 210×4	18	3	22	12,1	214	235	-	326	-	2,5	0,092	0,112
200	257	310	111	117	Tr 230×4	20	3	17,2	-	233	270	295	327	3,1	2,5	0,114	0,104
	251	306	138	152	Tr 230×4	20	3	20	10,1	233	250	-	327	-	2,5	0,095	0,113
	268	333	145	151	Tr 240×4	23	4	22,3	-	237	290	315	353	3,5	3	0,114	0,097
	259	350	130	136	Tr 240×4	20	4	20,5	-	237	295	320	383	1,7	3	0,113	0,101
220	276	329	116	123	Tr 260×4	21	3	19,2	-	253	290	315	347	1,3	2,5	0,113	0,106
	281	357	154	161	Tr 260×4	25	4	20,4	-	257	305	335	383	3,7	3	0,116	0,095
240	305	367	128	135	Tr 280×4	23	4	19,3	-	275	325	350	385	3,4	3	0,122	0,096
	314	394	172	179	Tr 280×4	26	4	26,4	-	277	340	375	423	4,1	3	0,115	0,096
260	328	389	131	139	Tr 300×4	24	4	21,3	-	295	350	375	405	1,8	3	0,121	0,098
	336	416	175	183	Tr 300×5	28	5	28,4	-	300	360	395	440	4,1	4	0,115	0,097
280	352	417	145	153	Tr 320×5	26	4	20	-	315	375	405	445	1,7	3	0,123	0,095
	338	409	184	202	Tr 320×5	24	4	30,4	-	315	360	400	445	2,8	3	0,105	0,106
	362	448	192	200	Tr 320×5	30	5	30,5	-	320	390	425	480	4,9	4	0,106	0,106
	354	448	224	242	Tr 320×5	24	5	14,9	-	320	353	424	480	3,4	4	-	0,097
300	376	440	149	157	Tr 340×5	27	4	23,3	-	335	395	430	465	1,8	3	0,121	0,098
	372	476	209	217	Tr 340×5	31	5	26,7	-	340	410	455	520	3,9	4	0,114	0,096
320	402	482	162	171	Tr 360×5	28	5	25,4	-	358	430	465	502	1,9	4	0,12	0,099
	405	517	225	234	Tr 360×5	33	5	25,9	-	360	445	490	560	4,2	4	0,118	0,093
340	417	497	167	176	Tr 380×5	30	5	26,4	-	378	445	480	522	2	4	0,12	0,099
	423	537	229	238	Tr 380×5	35	5	27,9	-	380	460	510	522	3,9	4	0,117	0,094

1) Width before the sleeve is driven into bearing bore

2) Permissible axial displacement from normal position of one bearing ring in relation to the other (→ page 40)

3) To clear the cage for caged bearings or to clear the snap ring for full complement bearings

4) To clear the cage for caged bearings

5) Minimum width of free space for bearings with the cage in normal position (→ page 18)

CARB toroidal roller bearings on a withdrawal sleeve

d_1 360 – 710 mm

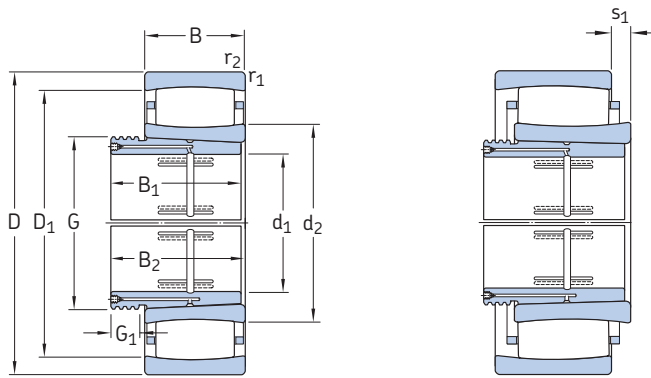

Principal dimensions			Basic load ratings		Fatigue load limit	Speed ratings		Mass	Designations	Withdrawal sleeve
d_1	D	B	C	C_0	P_u	Reference speed	Limiting speed	Bearing + sleeve	Bearing	
mm			kN		kN	r/min		kg	–	
360	560	135	3 000	5 200	390	900	1 200	130	▶ C 3076 KM C 3176 KMB	AOH 3076 G
	620	194	4 400	7 200	520	750	1 000	270		AOH 3176 G
380	600	148	3 650	6 200	450	800	1 100	165	▶ C 3080 KM C 3180 KM	AOH 3080 G
	650	200	4 800	8 300	585	700	950	285		AOH 3180 G
400	620	150	3 800	6 400	465	850	1 200	175	C 3084 KM C 3184 KM	AOH 3084 G
	700	224	6 000	10 400	710	800	1 100	380		AOH 3184 G
420	650	157	3 750	6 400	465	800	1 100	215	C 3088 KMB C 3188 KMB C 4188 K30MB	AOHX 3088 G
	720	226	6 700	11 400	780	630	850	420		AOHX 3188 G
	720	280	7 500	12 900	900	500	670	510		AOH 24188
440	680	163	4 000	7 500	510	700	950	230	C 3092 KM C 3192 KM C 4192 K30M	AOHX 3092 G
	760	240	6 800	12 000	800	600	800	480		AOHX 3192 G
	760	300	8 300	14 300	950	480	630	585		AOH 24192
460	700	165	4 050	7 800	530	670	900	245	▶ C 3096 KM C 3196 KMB	AOHX 3096 G
	790	248	6 950	12 500	830	560	750	545		AOHX 3196 G
480	720	167	4 250	8 300	560	630	900	265	C 30/500 KM C 31/500 KM C 41/500 K30MB	AOHX 30/500 G
	830	264	7 500	12 700	850	530	750	615		AOHX 31/500 G
	830	325	10 200	18 600	1 220	430	560	780		AOH 241/500
500	780	185	5 100	9 500	640	600	800	355	C 30/530 KM C 31/530 KM	AOH 30/530
	870	272	8 800	15 600	1 000	500	670	720		AOH 31/530
530	820	195	5 600	11 000	720	600	850	415	▶ C 30/560 KM C 31/560 KMB	AOHX 30/560
	920	280	9 500	17 000	1 100	530	750	855		AOH 31/560
570	870	200	6 300	12 200	780	500	700	460	C 30/600 KM C 31/600 KMB C 41/600 K30MB	AOHX 30/600
	980	300	10 200	18 000	1 140	430	600	1 020		AOHX 31/600
	980	375	12 900	23 200	1 460	340	450	1 270		AOHX 241/600
600	920	212	6 800	12 900	830	480	670	555	C 30/630 KM C 31/630 KMB	AOH 30/630
	1 030	315	11 800	20 800	1 290	400	560	1 200		AOH 31/630
630	980	230	8 150	16 300	1 000	430	600	705	▶ C 30/670 KM C 31/670 KMB	AOH 30/670
	1 090	336	12 000	22 000	1 320	380	530	1 410		AOHX 31/670
670	1 030	236	8 800	17 300	1 060	450	630	780	C 30/710 KM C 40/710 K30M ▶ C 31/710 KMB	AOHX 30/710
	1 030	315	10 600	21 600	1 290	400	560	1 010		AOH 240/710 G
	1 150	345	12 700	24 000	1 430	360	480	1 600		AOHX 31/710
710	1 090	250	9 500	19 300	1 160	380	530	975	C 30/750 KMB C 31/750 KMB	AOH 30/750
	1 220	365	13 700	30 500	1 800	320	450	1 990		AOH 31/750

▶ Please check availability of the bearing before incorporating it in a bearing arrangement design

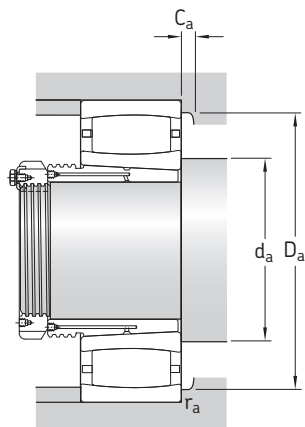

Dimensions							Abutment and fillet dimensions							Calculation factors		
d ₁	d ₂	D ₁	B ₁	B ₂ ¹⁾	G	G ₁	r _{1,2}	s ₁ ²⁾	d _a	d _a ³⁾	D _a ³⁾	D _a	C _a ⁴⁾	r _a	k ₁	k ₂
mm									mm				–			
360	431	511	170	180	Tr 400×5	31	5	27	398	460	495	542	2	4	0,12	0,1
	446	551	232	242	Tr 400×5	36	5	25,4	400	445	526	600	7,3	4	–	0,106
380	458	553	183	193	Tr 420×5	33	5	30,6	418	480	525	582	2,1	4	0,121	0,099
	488	589	240	250	Tr 420×5	38	6	50,7	426	526	564	624	2,5	5	0,106	0,109
400	475	570	186	196	Tr 440×5	34	5	32,6	438	510	550	602	2,2	4	0,12	0,1
	508	618	266	276	Tr 440×5	40	6	34,8	446	540	595	674	3,8	5	0,113	0,098
420	491	587	194	205	Tr 460×5	35	6	19,7	463	489	565	627	1,7	5	–	0,105
	522	647	270	281	Tr 460×5	42	6	16	466	521	613	694	7,5	5	–	0,099
	510	637	310	332	Tr 460×5	30	6	27,8	466	509	606	694	7,3	5	–	0,1
440	539	624	202	213	Tr 480×5	37	6	33,5	486	565	605	654	2,3	5	0,114	0,108
	559	679	285	296	Tr 480×6	43	7,5	51	492	570	655	728	4,2	6	0,108	0,105
	540	670	332	355	Tr 480×5	32	7,5	46,2	492	570	655	728	5,6	6	0,111	0,097
460	555	640	205	217	Tr 500×6	38	6	35,5	503	580	625	677	2,3	5	0,113	0,11
	583	700	295	307	Tr 500×6	45	7,5	24	512	580	705	758	20,6	6	–	0,104
480	572	656	209	221	Tr 530×6	40	6	37,5	523	600	640	697	2,3	5	0,113	0,111
	605	738	313	325	Tr 530×6	47	7,5	75,3	532	655	705	798	–	6	0,099	0,116
	598	740	360	383	Tr 530×6	35	7,5	15	532	597	703	798	4,4	6	–	0,093
500	601	704	230	242	Tr 560×6	45	6	35,7	553	635	685	757	2,5	5	0,12	0,101
	635	781	325	337	Tr 560×6	53	7,5	44,4	562	680	745	838	4,8	6	0,115	0,097
530	660	761	240	252	Tr 600×6	45	6	45,7	583	695	740	793	2,7	5	0,116	0,106
	664	808	335	347	Tr 600×6	55	7,5	28	592	660	810	888	23,8	6	–	0,111
570	692	805	245	259	Tr 630×6	45	6	35,9	623	725	775	847	2,7	5	0,125	0,098
	705	871	355	369	Tr 630×6	55	7,5	26,1	632	704	827	948	5,1	6	–	0,107
	697	869	413	439	Tr 630×6	38	7,5	24,6	632	696	823	948	5,5	6	–	0,097
600	717	840	258	272	Tr 670×6	46	7,5	48,1	658	755	810	892	2,9	6	0,118	0,104
	741	916	375	389	Tr 670×6	60	7,5	23,8	662	740	868	998	5,7	6	–	0,102
630	775	904	280	294	Tr 710×7	50	7,5	41,1	698	820	875	952	2,9	6	0,121	0,101
	797	963	395	409	Tr 710×7	59	7,5	33	702	795	965	1 058	28	6	–	0,104
670	807	945	286	302	Tr 750×7	50	7,5	47,3	738	850	910	1 002	3,2	6	0,119	0,104
	803	935	360	386	Tr 750×7	45	7,5	51,2	738	840	915	1 002	4,4	6	0,113	0,101
	848	1 012	405	421	Tr 750×7	60	9,5	34	750	845	1 015	1 100	28,6	8	–	0,102
710	854	993	300	316	Tr 800×7	50	7,5	28,6	778	852	961	1 062	7,4	6	–	0,11
	884	1 077	425	441	Tr 800×7	60	9,5	33	790	883	1 025	1 180	9,3	8	–	0,094

¹⁾ Width before the sleeve is driven into bearing bore

²⁾ Permissible axial displacement from normal position of one bearing ring in relation to the other (→ page 40)

³⁾ To clear the cage

⁴⁾ Minimum width of free space for bearings with the cage in normal position (→ page 18)

CARB toroidal roller bearings on a withdrawal sleeve

d_1 750 – 950 mm

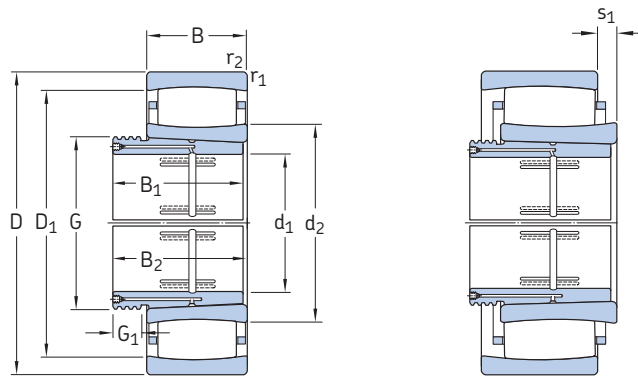

Principal dimensions			Basic load ratings		Fatigue load limit	Speed ratings		Mass Bearing + sleeve	Designations Bearing	Withdrawal sleeve
d_1	D	B	dynamic	static		Reference speed	Limiting speed			
mm			C	C_0	P_u	r/min		kg	–	
750	1 150	258	9 150	18 600	1 120	360	480	1 060	C 30/800 KMB ▶ C 31/800 KMB	AOH 30/800 AOH 31/800
	1 280	375	15 600	30 500	1 760	300	400	2 170		
800	1 220	272	11 600	24 500	1 430	320	450	1 300	C 30/850 KMB ▶ C 31/850 KMB	AOH 30/850 AOH 31/850
	1 360	400	16 000	32 000	1 830	280	380	2 600		
850	1 280	280	12 700	26 500	1 530	300	400	1 400	C 30/900 KMB	AOH 30/900
900	1 360	300	12 900	27 500	1 560	280	380	1 700	▶ C 30/950 KMB	AOH 30/950
950	1 420	308	13 400	29 000	1 630	260	340	1 880	▶ C 30/1000 KMB ▶ C 31/1000 KMB	AOH 30/1000 AOH 31/1000
	1 580	462	22 800	45 500	2 500	220	300	3 950		

▶ Please check availability of the bearing before incorporating it in a bearing arrangement design

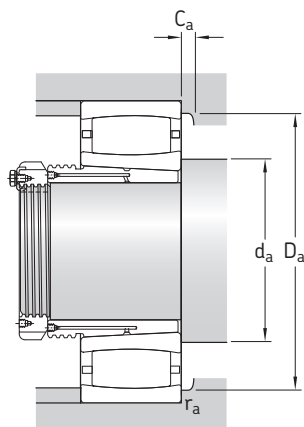

Dimensions							Abutment and fillet dimensions							Calculation factors		
d_1	d_2	D_1	B_1	$B_2^{1)}$	G	G_1	$r_{1,2}$	$s_1^{2)}$	d_a	$d_a^{3)}$	$D_a^{3)}$	D_a	$C_a^{4)}$	r_a	k_1	k_2
mm									mm				-			
750	888	1 076	308	326	Tr 850×7	50	9,5	36	790	885	1 080	1 180	31,5	8	-	0,117
	947	1 133	438	456	Tr 850×7	63	9,5	37	840	945	1 135	1 240	32,1	8	-	0,115
800	964	1 113	325	343	Tr 900×7	53	7,5	24	878	963	1 077	1 192	7,7	6	-	0,097
	1 020	1 200	462	480	Tr 900×7	62	12	40	898	1 015	1 205	1 312	33,5	10	-	0,11
850	1 004	1 173	335	355	Tr 950×8	55	7,5	25,5	928	1 002	1 124	1 252	3,3	6	-	0,1
900	1 080	1 240	355	375	Tr 1000×8	55	7,5	30	978	1 075	1 245	1 322	26,2	6	-	0,116
950	1 136	1 294	365	387	Tr 1060×8	57	7,5	30	1 028	1 135	1 295	1 392	26,7	6	-	0,114
	1 179	1 401	525	547	Tr 1060×8	63	12	46	1 048	1 175	1 405	1 532	38,6	10	-	0,105

¹⁾ Width before the sleeve is driven into bearing bore

²⁾ Permissible axial displacement from normal position of one bearing ring in relation to the other (→ page 40)

³⁾ To clear the cage

⁴⁾ Minimum width of free space for bearings with the cage in normal position (→ page 18)

Other associated SKF products

Self-aligning ball bearings

Self-aligning ball bearings as locating bearings are excellent partners for non-locating CARB toroidal roller bearings in self-aligning bearing systems if loads are light and speeds relatively high.

Self-aligning ball bearings were invented in 1907 by Sven Wingquist and SKF was founded to manufacture them. They are the low-friction bearings among rolling bearings and are still the optimum choice for many applications, even today. The SKF range covers all the usual dimension series and sizes for shafts from 5 to 240 mm in diameter. Most sizes are available with a tapered bore as well as a cylindrical bore and can therefore be mounted on the shaft in a variety of ways.

Spherical roller bearings

Spherical roller bearings are used in widely differing branches of industry as the locating bearing in self-aligning bearing systems when loads are heavy and speeds moderate. They are used successfully, e.g. in paper machines, for the roller beds of continuous casting plants as well as in ventilators and fans.

Spherical roller bearings are core products for SKF, as are self-aligning ball bearings, and were invented in 1919 by Arvid Palmgren and further developed in several stages by SKF. Today, the range produced by SKF comprises bearings in twelve dimension series with bore diameters ranging from 20 to 1 800 mm. All are available with cylindrical as well as tapered bores and some sizes are available in a sealed version.

Accessories

Lock nuts

Lock nuts (also referred to as shaft nuts) are mostly used to axially locate bearings at shaft ends and are produced by SKF to several designs. The KM, KML and HM nuts have four or eight slots equally spaced around the

circumference and are secured by locking washers or locking clips, that engage a groove in the shaft.

KMFE lock nuts with a locking screw were specially developed for use with CARB bearings and sealed spherical roller bearings and have dimensions appropriate to these bearings. They can therefore be mounted immediately adjacent to the bearings without impeding axial displacement within the bearing. A holding groove in the shaft is not needed.

KMT precision lock nuts with locking pins and KMK lock nuts with an integral locking device that do not require a groove in the shaft are also available.

Adapter and withdrawal sleeves

Adapter and withdrawal sleeves are used above all for bearing arrangements that have to be repeatedly mounted and dismantled. Bearings with a tapered bore can be mounted on smooth shafts as well as stepped shafts. They facilitate bearing mounting and dismounting and often simplify bearing arrangement design.

Adapter sleeves

Adapter sleeves are the more popular sleeves as they enable bearings to be mounted on smooth shafts as well as stepped shafts. When using adapter sleeves on smooth shafts it is possible to locate the bearing at any position on the shaft. When used on stepped shafts together with a spacer ring, exact axial positioning of the bearing can be achieved and bearing dismounting is facilitated.

SKF adapter sleeves are slotted and are supplied complete with nut and locking device and for smaller sizes also with a KMFE lock nut.

Withdrawal sleeves

Withdrawal sleeves can be used to mount bearings with a tapered bore on cylindrical seats of stepped shafts. The sleeve is pressed into the bore of the bearing, which abuts a shaft shoulder or similar fixed component. The sleeve is located on the shaft by a nut

or an end plate. SKF withdrawal sleeves are slotted and have an external taper of 1:12 or 1:30. The nuts required for mounting and dismantling the withdrawal sleeve are not supplied with the sleeve and must be ordered separately.



SKF withdrawal and adapter sleeves

SKF lock nuts



Bearing housings

Standard bearing housings together with rolling bearings provide economic bearing arrangements that require little maintenance. This is also true of CARB toroidal roller bearings. Mounted in standard housings the bearings are supported firmly and evenly around their circumference and across the whole raceway width. They are also protected against solid contaminants and moisture.

SKF produces a wide variety of bearing housings to meet different application demands. Most are made of grey cast iron, but housings of spheroidal graphite cast iron or cast steel can also be produced.

To meet the needs of bearing applications, for example in paper machines, housings to fit CARB bearings used at the non-drive side are available. These housings can be bolted to the bed as the thermal changes in cylinder length can be accommodated within the CARB toroidal roller bearing.

See also SKF catalogues

- “Bearing accessories”
- “Bearing housings”

and SKF brochures

- 6100 “SKF spherical roller bearings – setting a new standard for performance and reliability”
- 6101 “SNL 30, SNL 31 and SNL 32 plummer block housings solve the housing problems”
- 6111 “SONL plummer block housings – designed for oil lubrication”
- 6112 “SNL plummer block housings solve the housing problems”
- 6121 “SKF self-aligning bearing system”

or the

- “SKF Interactive Engineering Catalogue” online at www.skf.com



Lubricants and lubrication equipment

CARB toroidal roller bearings operate under a variety of loads, speeds, temperatures and environmental conditions. They require the type of high-quality lubricating greases, which SKF provides.

SKF greases have been specially developed for rolling bearings in their typical applications. The SKF assortment includes fifteen environmentally friendly greases and covers practically all application requirements.

The assortment is complemented by a selection of lubrication accessories including

- automatic lubricators
- grease guns
- lubricant metering devices
- a wide range of manually and pneumatically operated grease pumps.

Products for mounting and dismounting

Like all rolling bearings, CARB toroidal roller bearings require a high degree of skill when mounting or dismounting, as well as the correct tools and methods.

The comprehensive SKF assortment of tools and equipment includes everything that is required

- mechanical tools
- heaters
- hydraulic tools and equipment.



Mounting kit to apply the SKF drive-up method

See also SKF catalogue MP3000
"SKF Maintenance and Lubrication
Products" or online at
www.mapro.skf.com



*SKF lubricants:
the best choice for any bearing*

Condition monitoring equipment

The goal of condition monitoring is to maximize the time that a machine is functioning properly and minimize the number of unexpected breakdowns, thereby significantly reducing downtime and maintenance costs.

Condition monitoring enables incipient bearing damage to be detected and evaluated so that repairs can be scheduled for a time that will have a minimal impact on production. Applied to all critical machinery condition monitoring can optimize machinery utilization.

SKF provides a comprehensive range of condition monitoring equipment to measure important parameters. These include

- temperature
- speed
- noise
- oil condition
- shaft alignment
- vibration
- bearing condition.

Products range from lightweight, handheld devices, to sophisticated continuous monitoring systems for fixed installations that can be

connected directly to the plant's Computerized Maintenance Management System (CMMS).

One example is the MARLIN I-Pro data manager, which is a rugged, high performance data collector that enables plant operations personnel to quickly and easily collect, store and analyse overall machine vibration, process and inspection data. The unit enables trending, comparison with previous readings, alarm alerts and more. A "user notes" feature enables an operator to immediately record detailed observations of troublesome machine conditions or questionable measurements.

Taking the temperature



Checking vibration levels



MARLIN I-Pro data manager



SKF – the knowledge engineering company

From the company that invented the self-aligning ball bearing more than 100 years ago, SKF has evolved into a knowledge engineering company that is able to draw on five technology platforms to create unique solutions for its customers. These platforms include bearings, bearing units and seals, of course, but extend to other areas including: lubricants and lubrication systems, critical for long bearing life in many applications; mechatronics that combine mechanical and electronics knowledge into systems for more effective linear motion and sensorized solutions; and a full range of services, from design and logistics support to conditioning monitoring and reliability systems.

Though the scope has broadened, SKF continues to maintain the world's leadership in the design, manufacture and marketing of rolling bearings, as well as complementary products such as radial seals. SKF also holds an increasingly important position in the market for linear motion products, high-precision aerospace bearings, machine tool spindles and plant maintenance services.

The SKF Group is globally certified to ISO 14001, the international standard for environmental management, as well as OHSAS 18001, the health and safety management standard. Individual divisions have been approved for quality certification in accordance with ISO 9001 and other customer specific requirements.

With over 100 manufacturing sites worldwide and sales companies in 70 countries, SKF is a truly international corporation. In addition, our distributors and dealers in some 15 000 locations around the world, an e-business marketplace and a global distribution system put SKF close to customers for the supply of both products and services. In essence, SKF solutions are available wherever and whenever customers need them. Overall, the SKF brand and the corporation are stronger than ever. As the knowledge engineering company, we stand ready to serve you with world-class product competencies, intellectual resources, and the vision to help you succeed.



© Airbus – photo: e'm company, H. Goussé

Evolving by-wire technology

SKF has a unique expertise in fast-growing by-wire technology, from fly-by-wire, to drive-by-wire, to work-by-wire. SKF pioneered practical fly-by-wire technology and is a close working partner with all aerospace industry leaders. As an example, virtually all aircraft of the Airbus design use SKF by-wire systems for cockpit flight control.

SKF is also a leader in automotive by-wire technology, and has partnered with automotive engineers to develop two concept cars, which employ SKF mechatronics for steering and braking. Further by-wire development has led SKF to produce an all-electric forklift truck, which uses mechatronics rather than hydraulics for all controls.

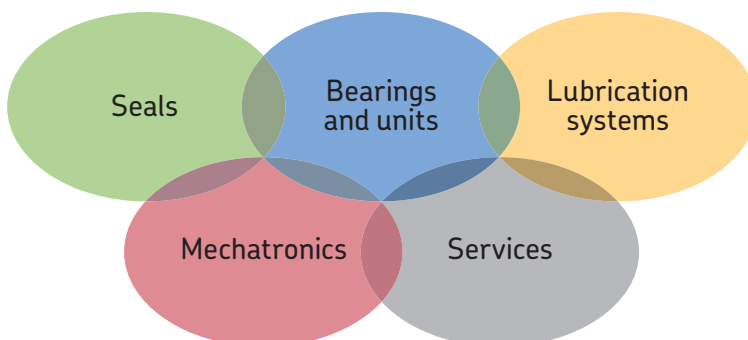



Harnessing wind power

The growing industry of wind-generated electric power provides a source of clean, green electricity. SKF is working closely with global industry leaders to develop efficient and trouble-free turbines, providing a wide range of large, highly specialized bearings and condition monitoring systems to extend equipment life of wind farms located in even the most remote and inhospitable environments.



Working in extreme environments

In frigid winters, especially in northern countries, extreme sub-zero temperatures can cause bearings in railway axleboxes to seize due to lubrication starvation. SKF created a new family of synthetic lubricants formulated to retain their lubrication viscosity even at these extreme temperatures. SKF knowledge enables manufacturers and end user customers to overcome the performance issues resulting from extreme temperatures, whether hot or cold. For example, SKF products are at work in diverse environments such as baking ovens and instant freezing in food processing plants.



Developing a cleaner cleaner

The electric motor and its bearings are the heart of many household appliances. SKF works closely with appliance manufacturers to improve their products' performance, cut costs, reduce weight, and reduce energy consumption. A recent example of this cooperation is a new generation of vacuum cleaners with substantially more suction. SKF knowledge in the area of small bearing technology is also applied to manufacturers of power tools and office equipment.



Maintaining a 350 km/h R&D lab

In addition to SKF's renowned research and development facilities in Europe and the United States, Formula One car racing provides a unique environment for SKF to push the limits of bearing technology. For over 50 years, SKF products, engineering and knowledge have helped make Scuderia Ferrari a formidable force in F1 racing. (The average racing Ferrari utilizes more than 150 SKF components.) Lessons learned here are applied to the products we provide to auto-makers and the aftermarket worldwide.



Delivering Asset Efficiency Optimization

Through SKF Reliability Systems, SKF provides a comprehensive range of asset efficiency products and services, from condition monitoring hardware and software to maintenance strategies, engineering assistance and machine reliability programmes. To optimize efficiency and boost productivity, some industrial facilities opt for an Integrated Maintenance Solution, in which SKF delivers all services under one fixed-fee, performance-based contract.



Planning for sustainable growth

By their very nature, bearings make a positive contribution to the natural environment, enabling machinery to operate more efficiently, consume less power, and require less lubrication. By raising the performance bar for our own products, SKF is enabling a new generation of high-efficiency products and equipment. With an eye to the future and the world we will leave to our children, the SKF Group policy on environment, health and safety, as well as the manufacturing techniques, are planned and implemented to help protect and preserve the earth's limited natural resources. We remain committed to sustainable, environmentally responsible growth.



© SKF, CARB, MARLIN, Microlog and SensorMount
are registered trademarks of the SKF Group.
™ SKF Explorer is a trademark of the SKF Group.

© SKF Group 2008
The contents of this publication are the copyright of the
publisher and may not be reproduced (even extracts)
unless permission is granted. Every care has been taken
to ensure the accuracy of the information contained in this
publication but no liability can be accepted for any loss or
damage whether direct, indirect or consequential arising
out of the use of the information contained herein.

Publication **6102 EN** · February 2008

This publication supersedes publication 5102.

Printed in Sweden on environmentally friendly paper.

skf.com